

**FLOOREQUIPMENTPARTS.COM**



# 1620

Carpet Maintainer

Patent No. : 5,611,106

**Model No.:**  
**607645**  
**607652 - Pac**

**Operator and Parts Manual**

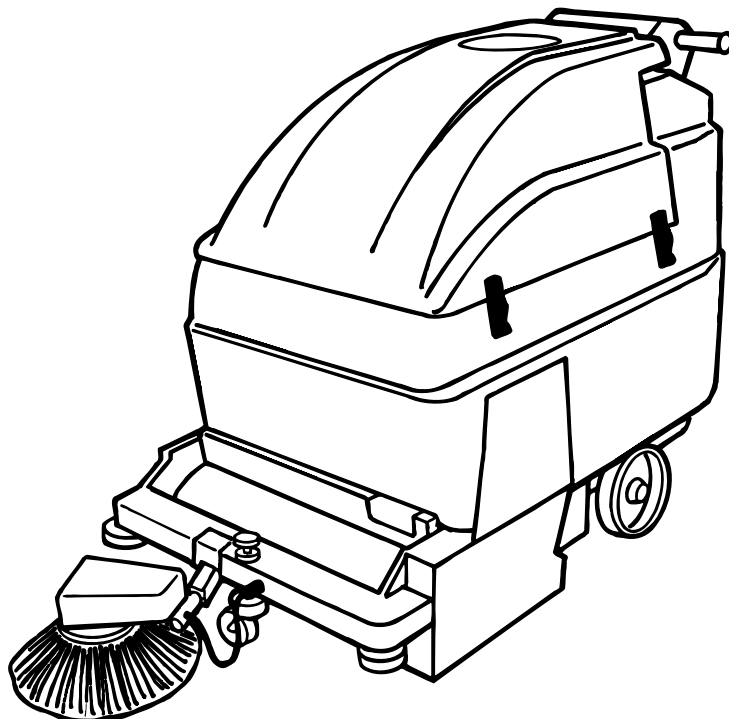

**TENNANT COMPANY**  
**Commercial Products**  
12875 RANSOM STREET  
HOLLAND MI 49424 U.S.A.

FAX: 1-800-678-4240  
CUSTOMER SERVICE: 1-800-982-7658

**607646**  
**Rev. 01 (04-00)**

# OPERATION

---

This manual is furnished with each new carpet maintainer. It provides necessary operation and maintenance instructions and an illustrated parts list.

**Read this manual completely and understand the machine before operating or servicing it.**

When ordering replacement parts, use the Parts Lists in this manual. Before ordering parts or supplies, be sure to have your machine model number and serial number handy. Parts and supplies may be ordered by phone or mail from any Authorized Service Center or Distributor.

This machine will provide excellent service. However, the best results will be obtained at minimum costs if:

- The machine is operated with reasonable care.
- The machine is maintained regularly - per the machine maintenance instructions provided.
- The machine is maintained with manufacturer supplied or equivalent parts.

---

## MACHINE DATA

---

Please fill out at time of installation for future reference.

Model No.- \_\_\_\_\_

Install. Date - \_\_\_\_\_

Serial No.- \_\_\_\_\_

© 1999, 2000 Tennant Company

Printed in U.S.A

Specifications and parts are subject to change without notice.

---

## TABLE OF CONTENTS

---

<b>SAFETY PRECAUTIONS</b> .....	<b>3</b>	<b>PARTS LIST</b> .....	<b>20</b>
<b>MACHINE COMPONENTS</b> .....	<b>4</b>	MAIN HOUSING GROUP .....	<b>20</b>
<b>CONTROL PANEL SYMBOLS</b> .....	<b>4</b>	CONTROL CONSOLE GROUP .....	<b>22</b>
<b>MACHINE INSTALLATION</b> .....	<b>5</b>	BRUSH GROUP .....	<b>24</b>
<b>CLEANING APPLICATIONS</b> .....	<b>6</b>	FAN/BRUSH MOTOR GROUP .....	<b>26</b>
<b>MACHINE SETUP</b> .....	<b>7</b>	ELECTRICAL PANEL GROUP .....	<b>28</b>
<b>MACHINE OPERATION</b> .....	<b>8</b>	HOPPER AND DRIVE GROUP .....	<b>30</b>
<b>ADJUSTING BRUSH HEIGHT</b> .....	<b>11</b>	PLUMBING GROUP .....	<b>32</b>
<b>CHARGING BATTERIES</b> .....	<b>11</b>	SIDE BRUSH GROUP .....	<b>34</b>
<b>MACHINE MAINTENANCE</b> .....	<b>13</b>	<b>ELECTRICAL DIAGRAMS</b> .....	<b>36</b>
<b>STORING MACHINE</b> .....	<b>15</b>	<b>OPTIONS</b> .....	<b>38</b>
<b>RECOMMENDED STOCK ITEMS</b> .....	<b>16</b>		
<b>TROUBLE SHOOTING</b> .....	<b>17</b>		
<b>SPECIFICATIONS</b> .....	<b>19</b>		

---

## SAFETY PRECAUTIONS

---

This machine is intended for commercial use. It is designed to sweep and maintain carpets in an indoor environment and is not constructed for any other use. Use only the Carpet Maintainer Formula with this machine.

All operators must read, understand, and practice the following safety precautions:

The following safety alert symbols are used throughout this manual as indicated in their description.

 **WARNING:** To warn of hazards or unsafe practices which could result in severe personal injury or death.

**FOR SAFETY:** To identify actions which must be followed for safe operation of equipment.

The following information signals potentially dangerous conditions to the operator or equipment:

### FOR SAFETY:

1. **Do not operate machine:**
  - Unless trained and authorized.
  - Unless operation manual is read and understood.
  - In flammable or explosive areas unless designed for use in those areas.
  - Without bag and/or filters in place.
2. **Before starting machine:**
  - Make sure all safety devices are in place and operate properly.
3. **When using machine:**
  - Do not pick up burning or smoking debris, such as cigarettes, matches or hot ashes.
  - Go slow on inclines and slippery surfaces.
  - Use care when reversing machine.
  - Always follow safety and traffic rules.
  - Place “WET FLOOR” signs when operating near hard floors.
  - Report machine damage or faulty operation immediately.
  - Follow mixing and handling instructions on chemical containers.
4. **Before leaving or servicing machine:**
  - Stop on level surface.
  - Turn off machine.

5. **When servicing machine:**
  - Avoid moving parts. Do not wear loose jackets, shirts, or sleeves.
  - Block machine tires before jacking machine up.
  - Use hoist or jack of adequate capacity to lift machine.
  - Disconnect battery connections before working on machine.
  - Wear protective gloves when handling batteries or battery cables.
  - Avoid contact with battery acid.
  - Use manufacturer supplied or approved replacement parts.

 **WARNING:** Batteries emit hydrogen gas. Explosion or fire can result. Keep sparks and open flame away. Keep battery compartment open when charging.

 **WARNING:** Flammable materials can cause an explosion or fire. Do not use flammable materials in tank(s).

 **WARNING:** Flammable materials or reactive metals can cause explosion or fire. Do not pick up.

 **WARNING:** Moving parts. Turn off power before working on machine.

# OPERATION

## MACHINE COMPONENTS

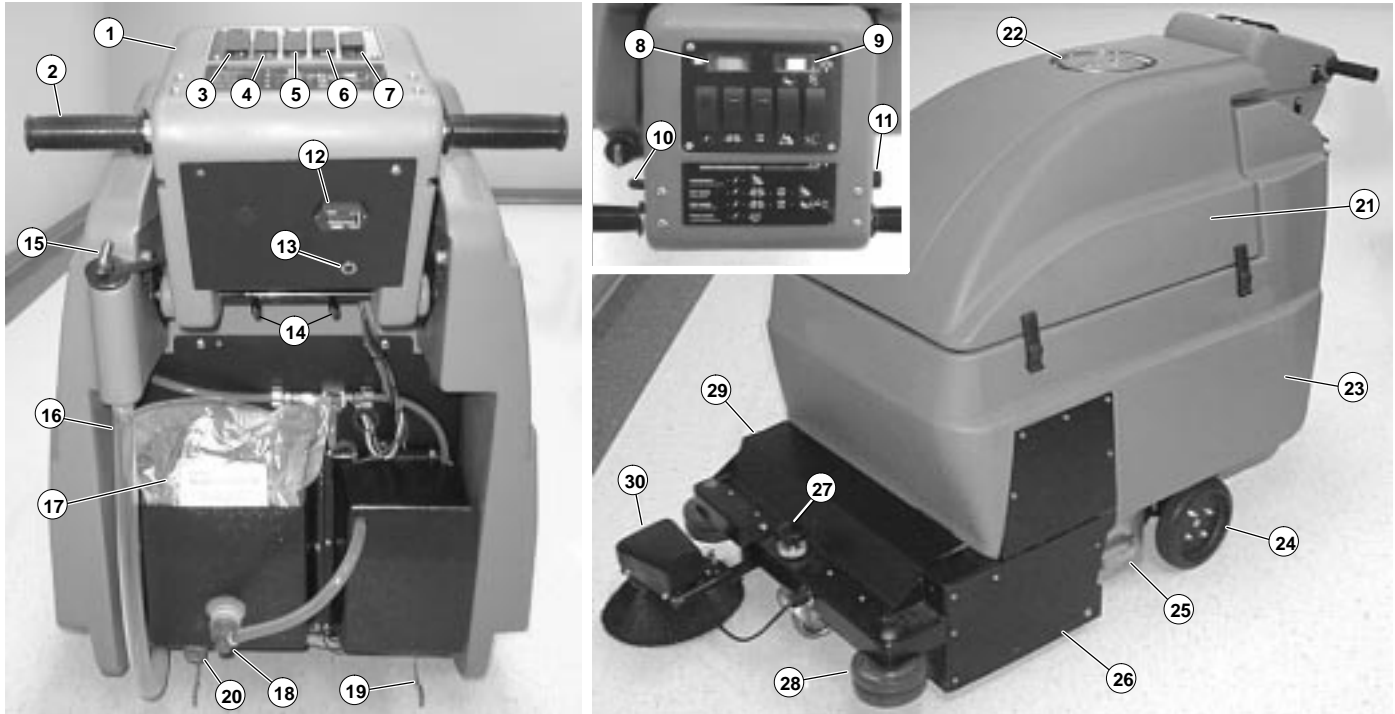

- |                             |                                      |                                  |
|-----------------------------|--------------------------------------|----------------------------------|
| 1. Control Console          | 11. Speed Control Knob               | 21. Battery Compartment Hood     |
| 2. Control Grips            | 12. Hour Meter                       | 22. Filter Bag Observation Cover |
| 3. Main Power ON/Off Switch | 13. Side Brush Breaker Button        | 23. Machine Housing              |
| 4. Dual Brush ON/OFF Switch | 14. Console Height Adjustment Levers | 24. Rear Driver Wheels           |
| 5. Side Brush ON/OFF Switch | 15. Solution Fill-Port Plug          | 25. Debris Hopper                |
| 6. Drive Switch             | 16. Solution Level Hose              | 26. Brush Housing                |
| 7. Solution Switch          | 17. Carpet Maintainer Formula Pouch  | 27. Brush Height Adjustment knob |
| 8. Battery Meter            | 18. Solution Dispenser Hose          | 28. Wall Rollers                 |
| 9. Brush Pressure Meter     | 19. Anti-Static Drag Chains          | 29. Spray Bar Cover              |
| 10. Reverse Trigger         | 20. Inline Clean Water Filter        | 30. Detachable Side Brush        |

## CONTROL PANEL SYMBOLS

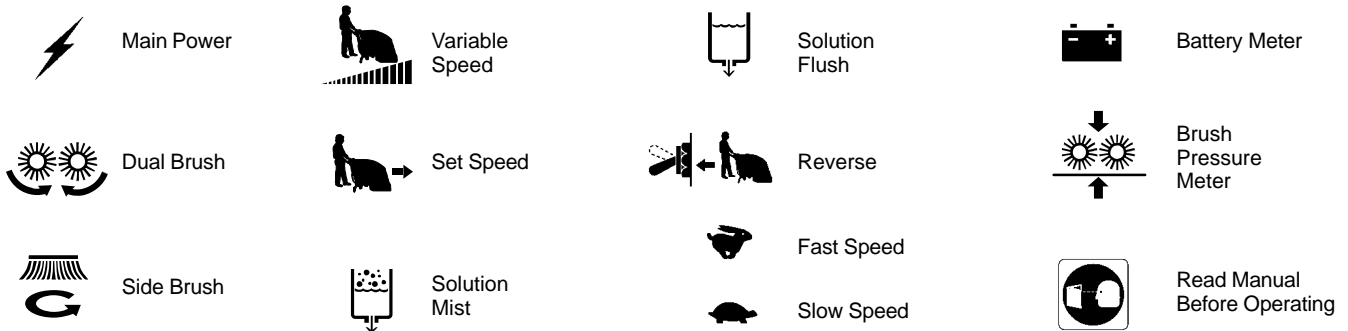

## MACHINE INSTALLATION

### UNCRATING MACHINE

Carefully check carton for signs of damage. Report damages to carrier at once.

To uncrate your machine, remove straps and carefully lift or use a ramp to remove machine from pallet.

**Do not roll machine off pallet, damage may occur.**

**ATTENTION: To prevent possible machine damage, install batteries *after* removing machine from pallet.**

Check Machine Contents to ensure package is complete, Contact Distributor for missing items.

#### Machine Contents:

- Battery Tray
- Battery Cable (taped to battery tray)
- Two Battery Spacers
- Filter Bag
- Secondary Filter
- Carpet Maintainer Formula Pouch
- Detachable Side Brush (boxed separately)
- Battery Compartment Metal Seal Plate
- Two 12V Batteries (Included with Pac 607652)
- Battery Charger (Included with Pac 607652)

### INSTALLING BATTERIES

**⚠ WARNING: Batteries emit hydrogen gas. Explosion or fire can result. Keep sparks and open flame away. Keep battery compartment open when charging.**

**FOR SAFETY: When servicing machine, wear protective gloves when handling batteries or cables. Avoid contact with battery acid.**

#### Recommended Battery Specifications:

Two 12 volt deep cycle 215 amp hour batteries. Part Number #600394. Maximum battery dimensions are 178mm(7 in)W x 394mm(15.5 in)L x 362mm(4.25in)H.

1. Park machine on a level surface and turn off all switches.

**FOR SAFETY: Before leaving or servicing machine, stop on level surface and turn off machine.**

2. Unlatch and open battery compartment hood. Remove metal seal plate covering battery compartment. Position battery tray and spacers as shown (Figure 1).

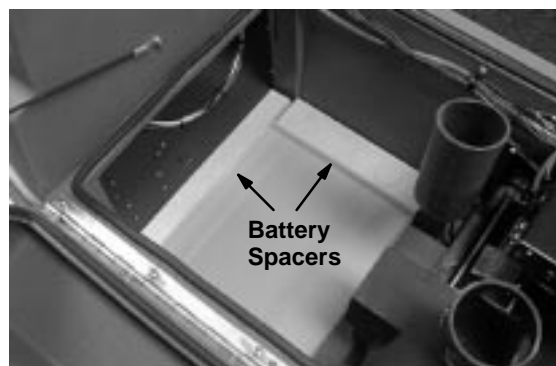

FIG. 1

3. Carefully position batteries into battery tray as shown (Figure 2).

**ATTENTION: Be careful not to drop batteries into compartment, damage may occur! Battery and machine housing damage is not covered by warranty.**

4. To ensure good terminal contact, clean battery posts and cable terminals with a wire brush. New batteries may have battery corrosion that is not visible to the eye.
5. Carefully connect battery cables as shown, red to positive and black to negative (Figure 2). Be certain that cable terminals are tight.

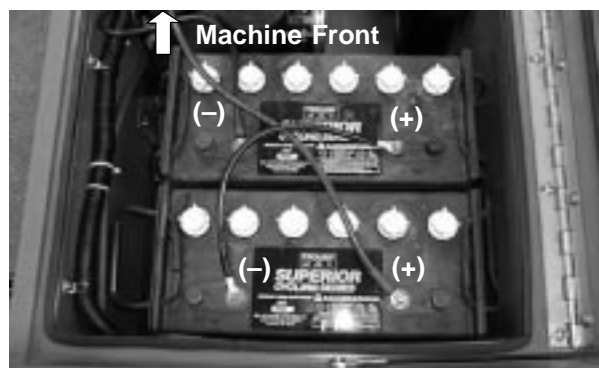

FIG. 2

6. Charge batteries (See CHARGING BATTERIES).
7. Replace metal seal plate, secondary filter and paper bag (Figure 3).

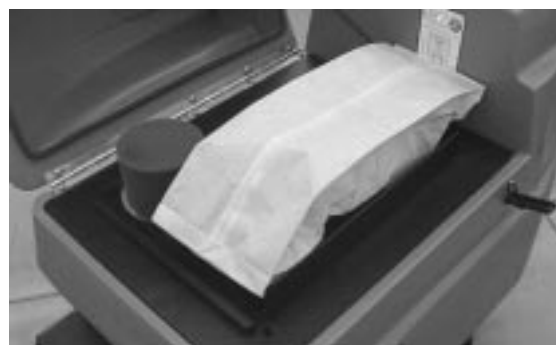

FIG. 3

# OPERATION

## INSTALLING DETACHABLE SIDE BRUSH

The side brush allows you to sweep dirt, dust and debris that collects along walls.

1. Park machine on a level surface and turn off machine.

**FOR SAFETY: Before leaving or servicing machine, stop on level surface and turn off machine.**

2. Align mounting hole on side brush arm with hole located next to brush adjustment knob as shown. Insert pin and secure with cotter pin provided (Figure 4).

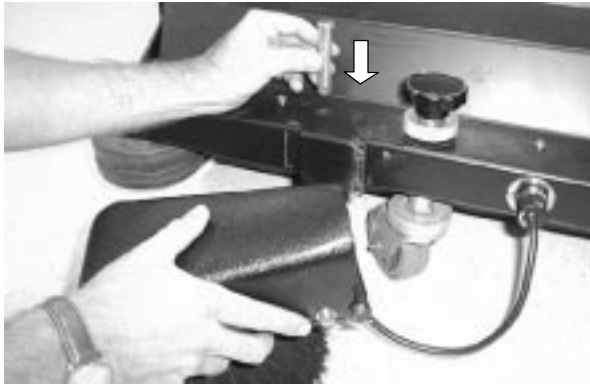

FIG. 4

**⚠ WARNING: Moving parts. Turn off power before working on machine.**

3. Plug side brush power cord into receptacle located on machine frame.
4. See ADJUSTING BRUSH HEIGHT for proper operating height.
5. To operate side brush, turn on machine and activate the side brush switch on the control console.
6. Swing up side brush to transport position when not in use (Figure 5).

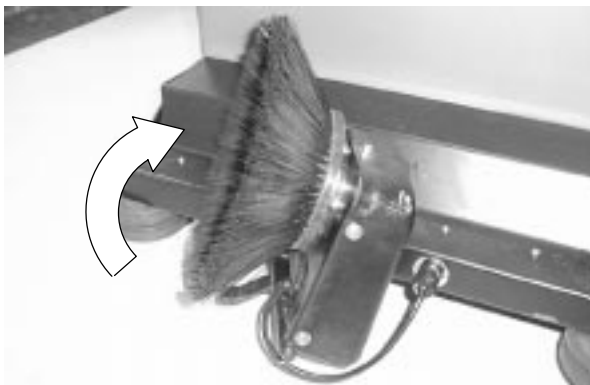

FIG. 5

## CLEANING APPLICATIONS

The carpet maintainer is designed to maintain large carpet areas by using the Dry and Mist Modes on a regular basis.

**Dry Mode Operation:** The counter rotating brushes remove surface soil, dust and debris while grooming the carpet fibers. The side brush collects dust and dirt along walls and trim. The pickup is directed into the hopper and the finer particles are collected in the filter bag.

**Mist Mode Operation:** A controlled mist of Carpet Maintainer Formula is applied onto the carpet. The counter rotating brushes work the solution into the fibers. The solution bonds to the soil and quickly dries. The encapsulated soil is removed during the next dry mode cleaning.

The machine is equipped with a user friendly operation guide located on the control panel. Simply follow the symbols for each operating mode (Figure 6).



FIG. 6

## DAILY CLEANING PROGRAMS

For best results, it is advised you begin your cleaning program with new or recently restored carpet.

Choose a recommended daily cleaning program that best meets your needs:

1. Moderate Traffic Areas: Use Mist Mode at mid-week and Dry Mode the other days.
2. High Traffic Areas: Alternate Dry and Mist Modes every other day.
3. Extremely High Traffic Areas: Use Dry Mode at mid-week and Mist Mode the other days to prevent soil buildup.

## MACHINE SETUP

### INSTALLING CARPET MAINTAINER FORMULA POUCH – MIST MODE

Each machine is equipped with one solution pouch. One pouch is equivalent to three solution tank fills or 60 gallons of water. To order more, contact your local distributor (#606025 Carpet Maintainer Formula– four pouches per case).

**ATTENTION: Only use the Carpet Maintainer Formula with the machine. Never use substitutes.**

1. Position solution pouch inside pouch holder located at rear of machine (Figure 7).



FIG. 7

2. Remove pouch cap and connect injector hose from machine to solution pouch.

### FILLING SOLUTION TANK – MIST MODE

1. Transport machine to filling station.
2. Park machine on a level surface and turn off machine.

**FOR SAFETY: Before leaving or servicing machine, stop on level surface and turn off machine.**

3. Twist off fill-port plug and fill solution tank with clean water, 60°C (140°F) maximum temperature (Figure 8). The fill-port tube shows water level. Solution tank capacity is 20 gallons.



FIG. 8

**⚠ WARNING: Flammable materials can cause an explosion or fire. Do not use flammable materials in tank(s).**

**NOTE: If filling with a bucket, be certain that bucket is clean. This will prevent possible solution line clogs. Use a funnel when filling with a bucket.**

### INSTALLING FILTER BAG

1. Unlatch battery compartment hood and open.
2. Install filter bag over vacuum outlet duct as shown (Figure 9).



FIG. 9

3. Be certain that secondary filter is installed on vacuum inlet duct (Figure 10).

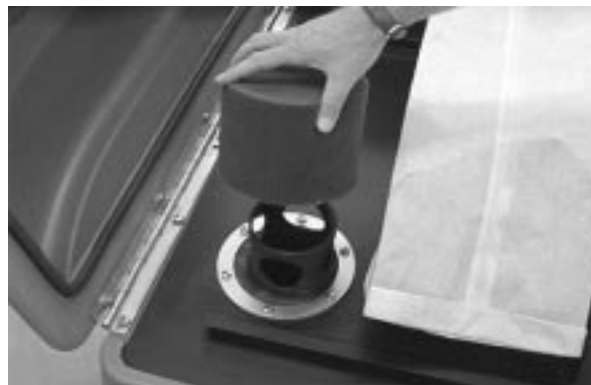

FIG. 10

# OPERATION

---

## ADJUSTING CONTROL GRIP HEIGHT

The machine has three control grip height settings.

1. Locate two spring loaded levers below console.
2. Squeeze levers together and lift or lower control grips to a comfortable operating height (Figure 11).

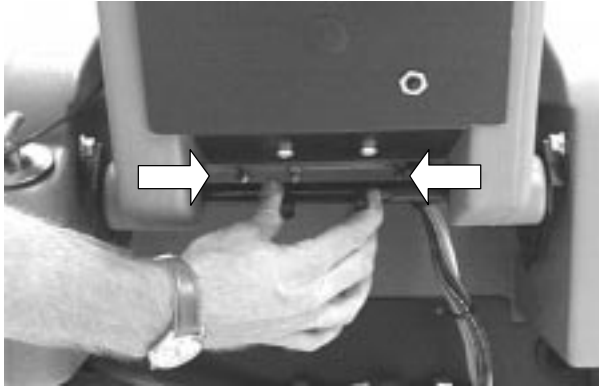

FIG. 11

---

## MACHINE OPERATION

---

**FOR SAFETY:** Do not operate machine unless operator manual is read and understood.

### PRE-OPERATION CHECKS

- Check battery meter discharge level.
- Check that filter bag is installed (look through clear lid).
- Check that hopper is in place and empty.
- Check that solution pouch is in place and connected.
- Inspect main brush for entangled debris.
- Check that spray bar is connected.
- Inspect spray tips for proper spray pattern (See Maintenance).

## TRANSPORTING MACHINE

1. Remove or swing up side brush to transport position.
2. Turn on main power switch and press drive switch toward the variable speed symbol (Figure 12).



FIG. 12

3. Turn speed control knob to slowest setting (Figure 13).



FIG. 13

4. To transport, roll control grips forward and gradually turn speed control knob to desired speed (Figure 14).



FIG. 14

**ATTENTION:** For first time users, operate at a slower speed until maneuvering becomes easy.



- To operate machine in reverse, simply pull reverse trigger (Figure 15).



FIG. 15

- To stop machine, release control grips.

## DRY MODE OPERATION

- Lower side brush from transport position.
- Turn on main power and both brush switches.
- Press drive switch toward the variable speed symbol (Figure 16).



FIG. 16

- Turn speed control knob to slowest setting (Figure 13).
- Roll control grips forward and gradually turn speed control knob to desired speed (Figure 14).

**ATTENTION: For first time users, operate at a slower speed until maneuvering becomes easy.**

- View brush pressure meter while operating. For optimum results, meter should read in the center of green zone (Figure 17). If brush pressure adjustment is necessary, see ADJUSTING BRUSH HEIGHT.

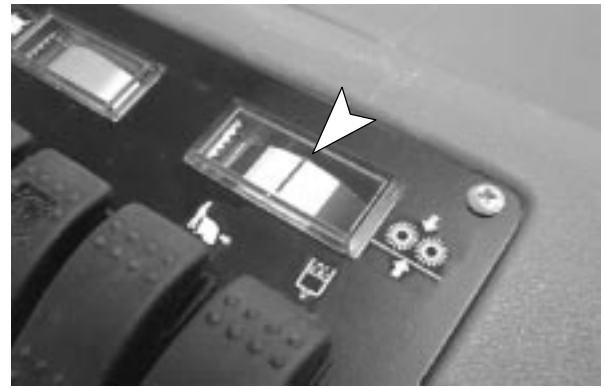

FIG. 17

- To operate machine in reverse, simply pull reverse trigger (Figure 15).
- To stop machine, release control grips.
- After cleaning, perform the Daily Maintenance procedures (See MACHINE MAINTENANCE).

## MIST MODE OPERATION

**FOR SAFETY: When using machine, place “WET FLOOR” signs when operating near hard floors.**

- Lower side brush from transport position.
- Turn on main power and both brush switches.
- Press drive switch toward the set speed symbol and solution switch toward the solution mist symbol (Figure 18).



FIG. 18

- Roll control grips forward to begin cleaning.

**NOTE: The solution mist is activated by the control grips. The mist injector system automatically mixes the Carpet Maintainer Formula to the proper dilution rate.**

- View brush pressure meter while operating. For optimum results, meter should read in the center of green zone (Figure 17). If brush pressure adjustment is necessary, see ADJUSTING BRUSH HEIGHT.
- To operate machine in reverse, pull reverse trigger.

# OPERATION

- To stop machine, release control grips.
- IMPORTANT: After mist mode cleaning, a 3–5 minute solution system flushing is recommended to prevent spray tip clogging.**

To flush solution system, press the solution switch toward the solution flush symbol for 3–5 minutes. You may either operate machine while flushing or position machine over a floor drain. Add extra water to solution tank if needed (Figure 19).

**ATTENTION: When flushing, do not leave machine stationary unless positioned over floor drain.**



FIG. 19

- After cleaning, allow 20 minutes for carpet to dry.
- Perform the Daily Maintenance procedures (See MACHINE MAINTENANCE).

## WHILE OPERATING MACHINE

**⚠ WARNING: Flammable materials or reactive metals can cause explosion or fire. Do not pick up.**

- Use caution when operating around walls or obstacles.
- Overlap each pass by 50mm (2 in).
- Periodically check battery meter discharge level. Recharge batteries when needle drops in red zone.

**ATTENTION: Do not operate machine when battery meter needle is in the red zone, battery damage will result.**

- When cleaning in mist mode, periodically check solution tank level and solution pouch.
- Periodically check hopper and filter bag. Empty when necessary.
- If the cleaning path leaves streaks in mist mode, spray tip cleaning is required.

**FOR SAFETY: When using machine, go slow on inclines and slippery surfaces.**

## CIRCUIT BREAKERS

The carpet maintainer is equipped with three circuit breakers to protect machine from damage.

- Main/drive Motor 15 amp. Breaker
- Brush/Fan Motor 60 amp. Breaker
- Side Brush Motor 1.5 amp. Breaker

If a breaker should trip during operation, determine cause and reset breaker by depressing breaker button.

The brush/fan motor circuit breaker is designed to stop current flow by manually pulling out breaker button. This will protect you from electric shock when servicing machine. Circuit breaker buttons are located under battery compartment hood. The side brush circuit breaker button is located on rear console panel (Figure 20).

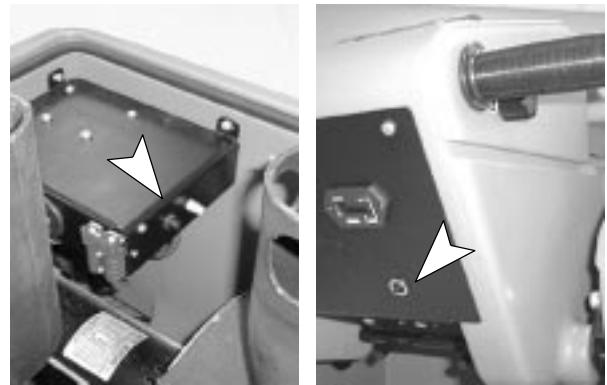

FIG. 20

## HOUR METER

The hour meter records number of hours the brushes have been turned on. Use hour meter to determine when to perform recommended maintenance procedures and to record service history (Figure 21).



FIG. 21

## ADJUSTING BRUSH HEIGHT

### MAIN BRUSH

1. For optimum cleaning results, adjust brush height so brush pressure meter reads in the center of green zone (Figure 22).

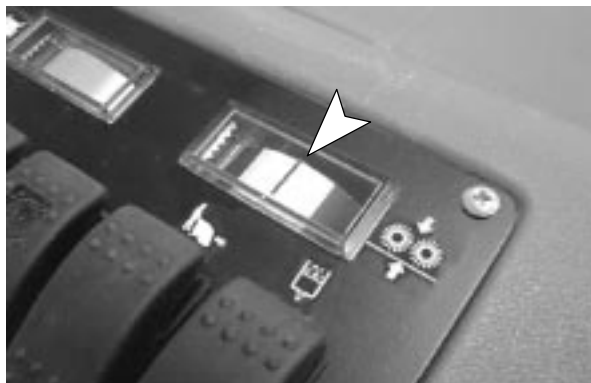

FIG. 22

2. To adjust brush height, turn off main power switch, loosen knurl locking ring below brush adjustment knob and turn knob clockwise to decrease or counter clockwise to increase pressure. Be certain to tighten down knurl locking ring and knob after adjusting, if necessary, use adjustable locking pliers to tighten knurl locking ring (Figure 23).

**FOR SAFETY:** Before leaving or servicing machine, stop on level surface and turn off machine.

**ATTENTION:** If knob and knurl locking ring works loose, the machine will vibrate downward and premature brush wear will result.



FIG. 23

### SIDE BRUSH

1. For optimum cleaning results, adjust side brush height so the outer 1/3 of the brush bristles touch the floor (Figure 24).

**⚠ WARNING:** Moving parts. Turn off power before working on machine.

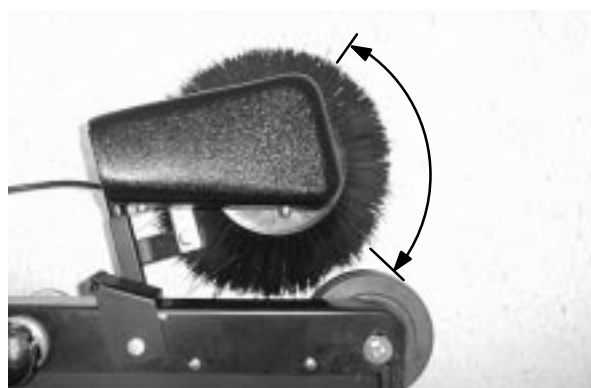

FIG. 24

2. To adjust side brush height, turn off main power switch, loosen nut on adjustment screw and turn screw clockwise to raise. Tighten down nut when properly adjusted (Figure 25).



FIG. 25

## CHARGING BATTERIES

**NOTE:** Recharge batteries *ONLY* after a total of 30 minutes of use or more. This will prolong battery life.

The following charging instructions are intended for supplied 24V chargers only. Or use a charger with the following specifications to prevent battery damage.

### CHARGER SPECIFICATIONS:

- OUTPUT VOLTAGE - 24 VOLTS
- OUTPUT CURRENT - 25 AMPS
- AUTOMATIC SHUTOFF CIRCUIT
- FOR DEEP CYCLE BATTERY CHARGING

**NOTE:** For optimum machine operation, keep batteries charged at all times. Never leave batteries discharged for lengthy periods.

# OPERATION

**⚠ WARNING: Batteries emit hydrogen gas. Explosion or fire can result. Keep sparks and open flame away. Keep battery compartment open when charging.**

**FOR SAFETY: When servicing machine, wear safety glasses when handling batteries or cables. Avoid contact with battery acid.**

**ATTENTION: To prevent battery damage, do not operate machine when battery meter reads in the red zone.**

1. Transport machine to a well ventilated area for charging.
2. Park machine on a level surface and turn off all switches.

**FOR SAFETY: Before leaving or servicing machine, stop on level surface and turn off machine.**

3. Unlatch and open battery compartment hood, remove filters and lift off metal seal plate (Figure 26).



FIG. 26

4. Check fluid level "A" in each battery cell. Do not charge batteries unless fluid is slightly covering battery plates "B". If needed, add just enough distilled water to cover battery plates, do not overfill. Batteries can overflow during charging due to expansion. Replace cell caps before charging (Figure 27).

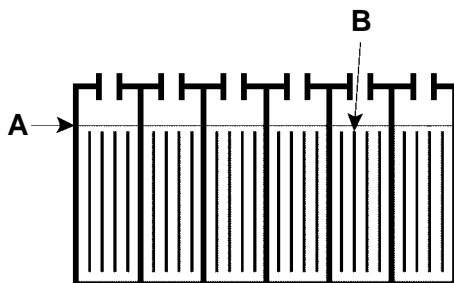

FIG. 27

5. With charger disconnected from machine, plug charger's power cord into a grounded wall outlet (Figure 28).

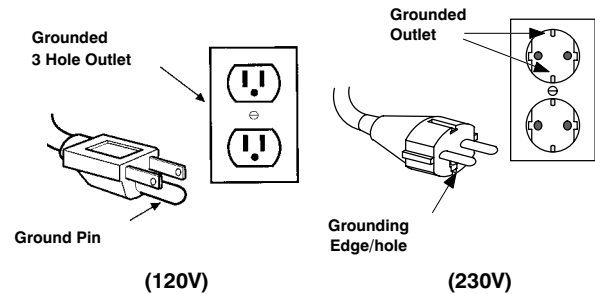

FIG. 28

6. Plug battery charger into machine's charging receptacle as shown (Figure 29).



FIG. 29

**⚠ WARNING: Batteries emit hydrogen gas. Explosion or fire can result. Keep sparks and open flame away. Keep battery compartment open when charging.**

**NOTE: Once charger is connected, machine becomes inoperable.**

7. Charger will automatically begin charging and shut off when fully charged.
8. When disconnecting charger, always unplug charger from wall outlet first.
9. After charging, check battery fluid level. Fluid level should reach bottom of sight tubes. If needed, add distilled water. DO NOT fill beyond bottom of sight tube.

## MACHINE MAINTENANCE

To keep machine in good working condition, simply follow the daily, weekly, and monthly maintenance procedures.

**FOR SAFETY: Before leaving or servicing machine, stop on level surface and turn off machine.**

**FOR SAFETY: When servicing machine, disconnect battery connections before working on it.**

**ATTENTION: Contact an Authorized Service Center for machine repairs. Machine repairs performed by other than an authorized person will void your warranty.**

### DAILY MAINTENANCE (Every 4 Hours of Operation)

1. After using the Mist Mode , a 3–5 minute solution system flushing is recommended to prevent spray tip clogging. To flush solution system, press the solution switch toward the solution flush symbol for 3–5 minutes. You may either operate machine while flushing or position machine over a floor drain. Add extra water to solution tank if needed.

**ATTENTION: When flushing, do not leave machine stationary unless positioned over floor drain.**

2. Recharge batteries (See CHARGING BATTERIES).

**NOTE: Recharge batteries ONLY after a total of 30 minutes of use or more. This will prolong battery life.**

3. Drain leftover solution in solution tank. Pull fill-port tube off hose barb and drain into floor drain or bucket (Figure 30). Tilt machine back to completely drain.



FIG. 30

4. Empty and rinse out hopper (Figure 31).



FIG. 31

5. Inspect filter bag. If bag's inner surface is completely coated with debris replace with new bag (Figure 32).



FIG. 32

6. Inspect brushes for entangled debris.
7. Clean machine with an all purpose cleaner and damp cloth.

**ATTENTION: Do not power spray or hose off machine. Electrical component damage due to water is not covered by warranty.**

### WEEKLY MAINTENANCE (Every 20 Hours of Operation)

1. Check fluid level in battery cells (See Battery Maintenance).
2. Clean battery tops to prevent corrosion (See Battery Maintenance).
3. Check for loose or corroded battery cables.
4. Remove inline strainer filter and clean. Make sure solution is empty before removing filter (Figure 33).



FIG. 33

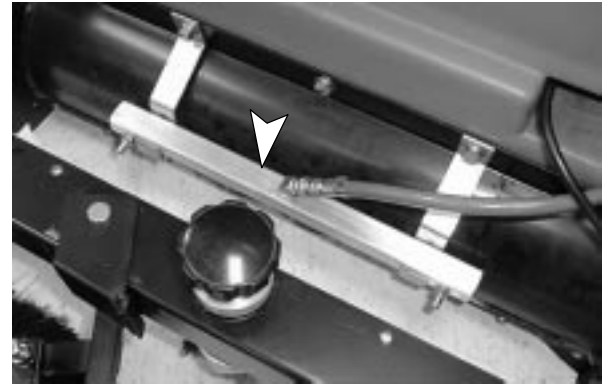

FIG. 35

5. Perform a hot water solution system flush:
  - a. Empty existing water from solution tank and refill with 20L (5 gal.) of hot clean water; 60°C (140°F) maximum temperature.
  - b. Position machine over a floor drain.
  - c. Activate main power switch and press solution switch toward solution flush symbol. Operate Machine System Flush Mode until solution tank is empty (10–15 minutes). Inspect for proper spray pattern while flushing (See step 6.).
6. Inspect spray tips for proper spray pattern:
  - a. Fill solution tank with 4L (1 gal.) of clean water and position machine over a floor drain.
  - b. Remove spray bar cover at front of machine.
  - c. Operate Machine System Flush Mode and observe spray pattern. Pattern should fan out evenly across the width of the spray bar (Figure 34).

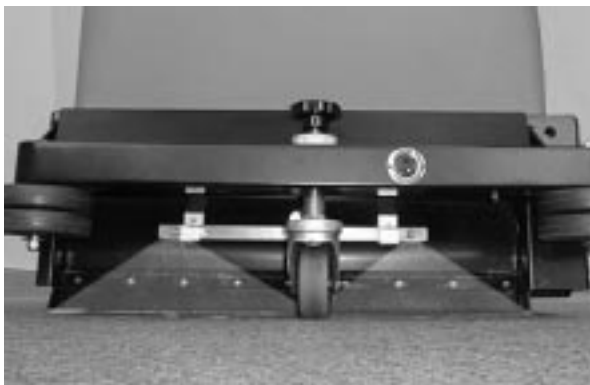

FIG. 34

- d. If spray pattern is uneven proceed to next step.
- e. Remove detachable spray bar from machine. Remove spray tips from spray bar and soak in a tannin solution for up to 2 hours. After soaking tips, use a small brush to remove excess alkaline and rinse thoroughly. DO NOT use pointed objects to unplug spray tips (Figure 35).

7. Inspect brushes for wear. Replace if worn.

## MONTHLY MAINTENANCE (Every 80 Hours of Operation)

1. Perform a tannin/hot water solution system flush:
  - a. Pour 11.3L (3 gal) of hot water into solution tank; 60°C (140°F).
  - b. Add a tannin solution according to mixing directions on bottle.
  - c. Position machine over a floor drain.
  - d. Activate main power switch and press solution switch toward solution flush symbol. Operate Machine System Flush Mode for 30–60 seconds. Shut off power and let machine sit overnight.
  - e. Next day, disperse remaining tannin/solution and flush machine with clean water.

## FOR SAFETY: When using machine, follow mixing and handling instructions on chemical containers.

2. Remove secondary filter, located under battery compartment hood, and tap out dust.
3. Lubricate front caster grease fitting with a water resistant grease.
4. Remove right side brush mount plate and inspect brushes for wear, replace brushes if necessary. Remove any string or debris entangled around brushes, pulleys, or posts of mounting plate. Using a putty knife, scrape any debris from brush housing.
5. Inspect battery compartment hood gasket for damage.
6. Check dust skirts at front, rear and sides of main brushes for wear or damage.
7. Check machine for solution leaks and loose nuts and bolts.
8. Check static drag chains for wear and floor contact.

## QUARTERLY MAINTENANCE (Every 250 Hours of Operation)

Check motors for carbon brush wear, replace carbon brushes if worn to a length of 10mm (0.38 in) or less.

Contact an Authorized Service Center for motor maintenance.

## BATTERY MAINTENANCE

**⚠ WARNING: Batteries emit hydrogen gas. Explosion or fire can result. Keep sparks and open flame away. Keep battery compartment open when charging.**

**FOR SAFETY: When servicing machine, wear safety glasses when handling batteries or cables. Avoid contact with battery acid.**

1. Always follow proper charging instructions (See CHARGING BATTERIES).
2. After charging batteries, check fluid level (A) in each battery cell. Fluid level should reach bottom of sight tubes (B). If needed, add distilled water. DO NOT fill beyond bottom of sight tube (Figure 36).

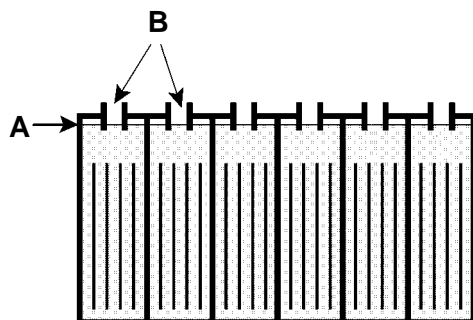

FIG. 36

3. Keep battery tops and terminals clean and dry.  
To clean batteries:
  - a. Mix a strong solution of baking soda and water (Figure 37).



FIG. 37

- b. Brush solution sparingly over battery tops, terminal and cable connectors.

**NOTE:** Do not allow baking soda solution to enter battery cells.

- c. Use wire brush to clean terminal post and cable connections.
- d. After cleaning, apply a coating of clear battery post protectant to terminals and cable connections.

## STORING MACHINE

When storing machine for extended periods of time, follow the procedures below:

1. Charge Batteries. Never store machine with discharged batteries.
2. Drain solution tank.
3. Remove solution pouch.
4. Empty hopper of debris.
5. Store machine in a dry area.
6. Raise brushes off floor.
7. If storing machine in freezing temperatures (See STORING MACHINE IN FREEZING TEMPERATURES).

**ATTENTION: Do not allow machine to freeze with water in solution system. Damage due to freezing temperatures is not covered by warranty.**

**ATTENTION: Do not expose machine to rain; store indoors.**

# OPERATION

## STORING MACHINE IN FREEZING TEMPERATURES

When storing machine in freezing temperatures, the following procedures must be followed to prevent solution system damage:

1. Disconnect solution pouch from machine and store indoors (Figure 38).



FIG. 38

2. Operate Mist Mode for 30 seconds to clear solution system.
3. Operate Machine System Flush Mode for 3 minutes.
4. Drain solution tank of all water, tilt back machine to completely drain (Figure 39).



FIG. 39

5. Remove filter bowl, located under machine, and empty (Figure 40).



FIG. 40

6. Disconnect spray bar and shake out water through spray tips (Figure 41).

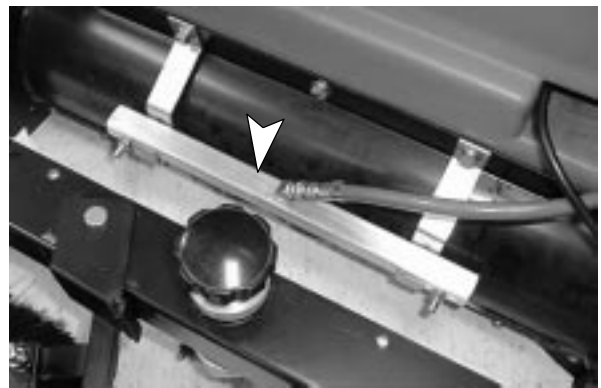

FIG. 41

## RECOMMENDED STOCK ITEMS

Refer to Parts List section for recommended stock items. Stock Items are clearly identified with a bullet preceding the parts description. See example below:

Ref.	Part No.	Description	Qty.
1	201183	ASB_STANDPIPE	1
2	388513	•FLOW, SHUTOFF	1
3	228187	•NIPPLE	1
4	101714	•GASKET	1
5	218248	•NUT, FLANGED	1



## TROUBLE SHOOTING

PROBLEM	CAUSE	SOLUTION
Machine does not operate.	Faulty main switch.	Contact Service Center.
	Batteries need charging.	See Charging Batteries.
	Faulty battery(s).	Replace battery(s).
	Loose battery cable.	Tighten loose cable.
	Main circuit breaker tripped.	Determine cause and reset circuit breaker button.
Brush motor does not run.	Control grips are not rotated.	Rotate control grips.
	Brush circuit breaker has tripped or is pulled out.	Remove obstruction from brush and reset brush circuit breaker button.
	Faulty brush motor or wiring.	Contact Service Center.
	Carbon brushes worn.	Contact Service Center.
	Loose or broken belt.	Replace, or contact Service Center.
	Faulty brush switch,	Contact Service Center.
Drive motor does not operate.	Faulty speed control board or connection.	Contact Service Center.
	Faulty solenoid.	Contact Service Center.
	Faulty drive motor.	Contact Service Center.
	Faulty switch or wiring.	Contact Service Center.
	Worn carbon brushes.	Contact Service Center.
Drive motor operates incorrectly.	Faulty potentiometer or speed control board.	Contact Service Center.
	Loose wire connection.	Contact Service Center.
Poor sweeping performance.	Worn brush.	Replace brush. Contact Service Center.
	Brush not adjusting for wear.	Adjust brush. Contact Service Center.
	Brush not level with floor.	Contact Service Center.
	Hopper full.	Empty Hopper.
	Dust filter bag clogged.	Replace bag.
	Brush jammed with debris.	Remove jam.
	Dust skirt damaged.	Replace if damaged.
	Brush drive belts slipping or broken.	Contact Service Center.
	Battery compartment seals and gaskets are defective.	Replace seals and gaskets.
	Hood lid is loose.	Tighten lid.
	Battery charge level is low.	Charge batteries. Do not run machine when battery meter is in the red zone.

*Continued on next page.*

# OPERATION

## TROUBLE SHOOTING –Continued

PROBLEM	CAUSE	SOLUTION
Dusting	Dirty filter bag.	Replace bag.
	Filter not installed correctly.	Install filter correctly.
	Damaged filter bag.	Replace bag.
	Hopper full.	Empty hopper.
	Clogged intake and outlet air ducts.	Clean out.
	Damaged air duct seal rings.	Replace seal rings.
	Blower wheel not operating.	Check for fan drive sheave slipping on its shaft, or impeller key is broken.
Uneven or no solution spray.	Spray tips are plugged.	Remove and clean.
	Control grips are not rotated.	Rotate control grips.
	Solution system is clogged.	Flush system with an alkaline detergent.
	Inline strainer filter is plugged.	Drain solution tank, remove filter and clean. Located under machine at rear.
	Faulty pump switch.	Contact Service Center.
	Faulty pump or solenoid.	Contact Service Center.
Formula does not draw out of pouch.	Formula pouch cap is loose.	Cap must be fully threaded on pouch.
	Build-up on spray tips.	Inspect/clean spray tips (See Weekly Maintenance).
	Injector metering tip is clogged.	Remove tip from hose and clean.
	Injector or 3-way valve clogged.	Remove and clean.
Short run time.	Batteries not fully charged.	Charge batteries.
	Defective batteries.	Replace battery.
	Batteries need maintenance.	See Battery Maintenance.
	Faulty charger.	Replace battery charger.

---

**SPECIFICATIONS**

<b>MODEL</b>	<b>1620</b>
LENGTH	1550mm (61 in)
WIDTH	787mm (31 in)
HEIGHT	1016mm (40 in)
WEIGHT	141Kg (310 lb) 251kg (554 lb) w/ batteries
SOLUTION TANK CAPACITY	76L (20 Gal)
SOLUTION PUMP	6.9 bar (100 psi) max., 24V
SOLUTION FLOW RATE	1.5L (0.4 Gal) per minute
SPEED CONTROL	Transporting/Dry Mode–variable speed / Mist Mode–set speed
CLEANING SPEED (MAX)	Dry Mode – 2044m <sup>2</sup> (22,000 sq ft) per hour Mist Mode – 1022m <sup>2</sup> (11,000 sq ft) per hour
CLEANING PATH WIDTH	762mm (30 in) includes side brush
DRIVE SYSTEM	Transaxle, .2 hp, 24V
BRUSH/WHEEL BLOWER MOTOR	1.5 hp, 1725 rpm, 24V, 50A, 1119W
BATTERIES	2–12V, 215AH
RUN TIME PER CHARGE	Up to 3 hours
DECIBEL RATING AT OPERATOR'S EAR, INDOORS ON CARPET	67dB(A)

# PARTS LIST

## MAIN HOUSING GROUP

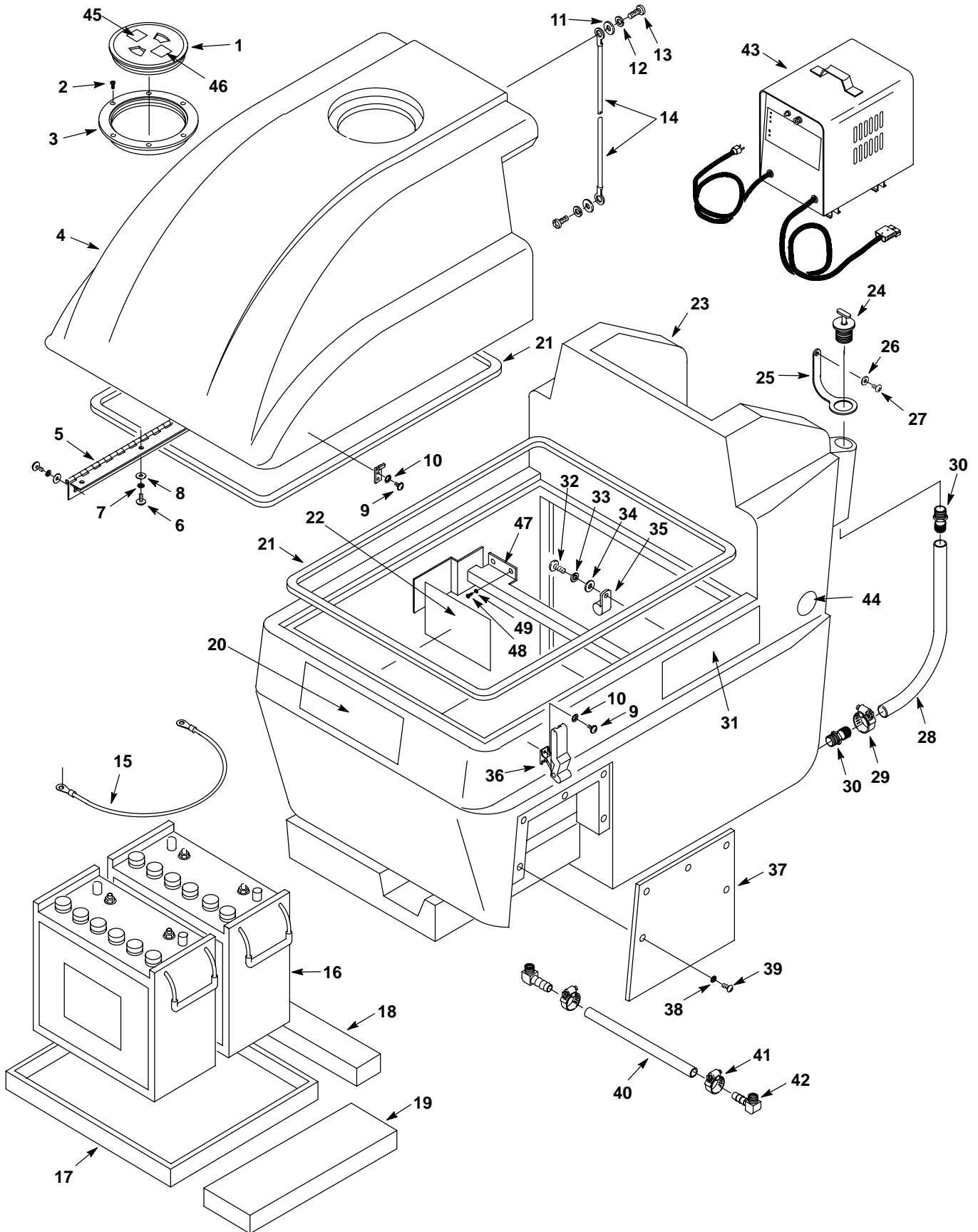

## MAIN HOUSING GROUP

REF	PART #	DESCRIPTION	QTY.
1	100105	LID, CENTER, CLEAR	1
2	140826	SCREW, #6 X 3/4	6
3	100109	LID, OUTER RING, BLACK	1
4	607698	HOUSING, COVER, TEAL	1
5	231015	HINGE, COVER	1
6	578187000	SCREW, M6X1.0X12	10
7	578244000	WASHER, LOCK, INT, 0.25	10
8	140000	WASHER, 1/4 FLAT	10
9	200630342	SCREW, M4X.7X10	8
10	140023	WASHER, #8 INT	8
11	140000	WASHER, 1/4 FLAT	2
12	578244000	WASHER, 6.4X10.0 LOCK	2
13	578187000	SCREW, M6X1.0X12	2
14	630021	CABLE ASSY, TANK SUPPORT, 20.5"	1
15	130364	CABLE, BATT. #6 BLACK X 15" 5/16 X 3/8	1
16	600394	BATTERY, 12V 215AH	2
17	606407	TRAY, BATTERY	1
18	606253	SPACER, BATTERY, LONG	1
19	606254	SPACER, BATTERY, SHORT	1
20	120192	DECAL, "TENNANT"	1
21	606358	●GASKET, 3/8 X 7/16 X 102"	2
22	603233	DECAL, BATTERY DIAGRAM	1
23	607696	HOUSING, CHASSIS, TEAL	1
24	621324	●PLUG, EXPANSION 1-1/2" DIA	1
25	600476	●STRAP, PLUG REAR FILL	1

REF	PART #	DESCRIPTION	QTY.
26	140007	●WASHER, #8 FLAT	1
27	140350	●SCREW, #10X1/2	1
28	606076	HOSE, SOLUTION TANK DRAIN	1
29	630369	CLAMP, HOSE	1
30	150529	FITTING, 3/4M X 3/4H BARB	2
31	608157	DECAL, "1620"	2
32	578141000	SCREW, M5X.8X10	2
33	140018	WASHER, #10 INT	2
34	140011	WASHER, 3/16 FLAT	2
35	630428	CLAMP, CABLE 1.0"DIA., 1/4"MOUNT	2
36	140932	●LATCH, HOOD RUBBER W/ KEEPER	2
37	605860	PLATE, COVER UPPER	1
38	140018	WASHER, #10 INT	5
39	578141000	SCREW, M5 X .8 X 10	5
40	606238	TUBING, MAYON PLAS 3/8 X 18"	1
41	140310	CLAMP, HOSE 5/16-7/8	2
42	150419	FITTING, 1/4MX3/8H ELBOW 90°	2
43	603235	CHARGER, 24DC/20A/120AC	1
44	N/A	DECAL, PREVENTIVE	1
45	606105	DECAL, DO NOT SPRAY	1
46	578729	DECAL, READ MANUAL	1
47	607029	BRACE, TANK	1
48	578141000	SCREW, M5X10	2
49	140018	WASHER, #10 INT	2

● RECOMMENDED STOCK ITEMS

CONTROL CONSOLE GROUP

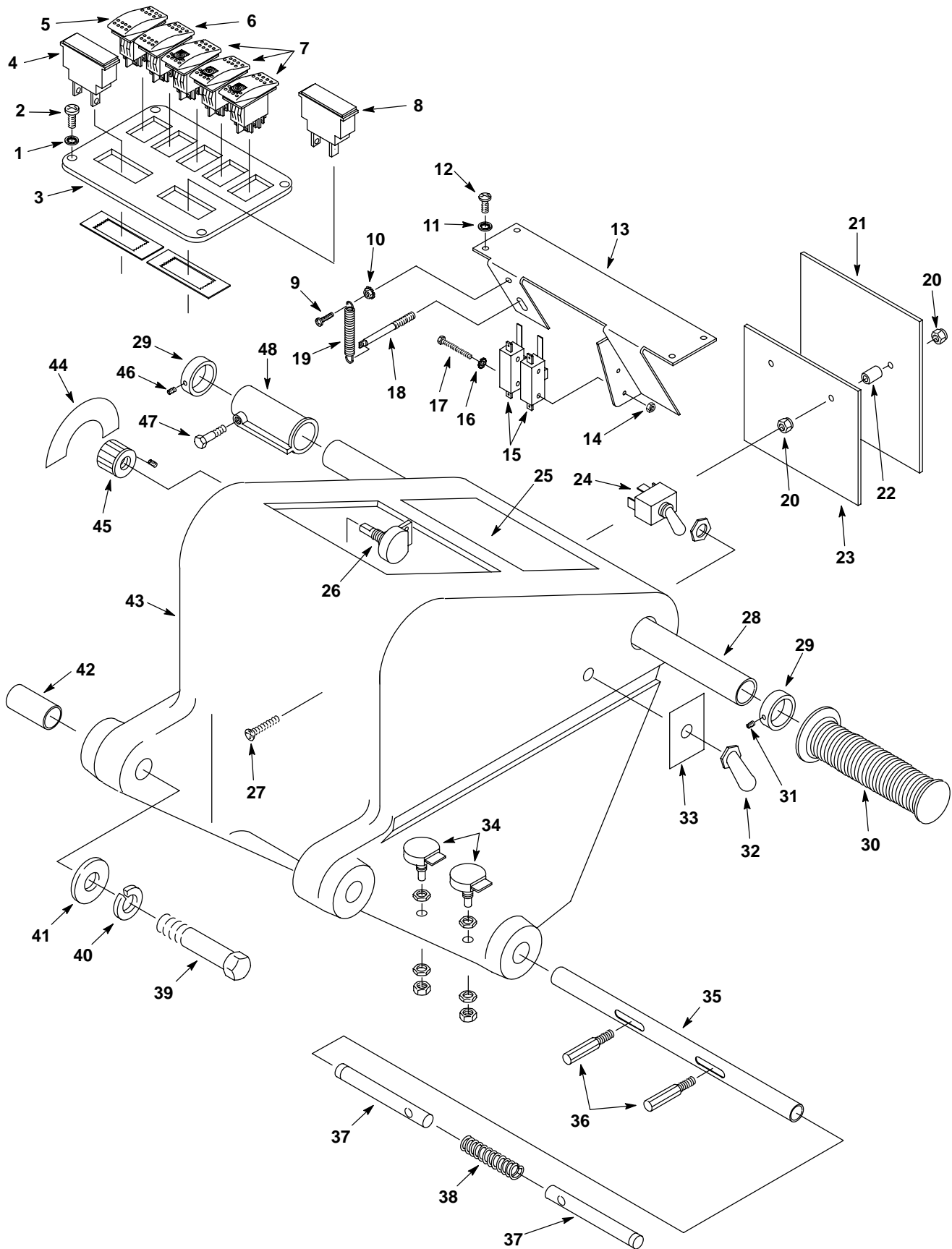

## CONTROL CONSOLE GROUP

REF	PART #	DESCRIPTION	QTY.
1	140018	WASHER, #10 INT	4
2	578141000	SCREW, M5 X .8 X 10	4
▽	606089	ASM, PANEL W/ SWITCHES	1
▲3	606018	PANEL	1
▲4	606019	GAUGE, BRUSH PRESSURE	1
▲5	609657	●SWITCH, ROCKER ON/OFF/ON	1
▲6	602919	●SWITCH, DPDT ON/ ON	1
▲7	601107	●SWITCH, LIGHTED ROCKER	3
▲8	606020	METER, BATTERY VOLTAGE 24V	1
9	140268	SCREW, M5 X .8 X 12	1
10	575540000	NUT, M5	1
11	140018	WASHER, #10 INT	4
12	578144000	SCREW, M5 X 16	4
13	605957	BRACKET, ROLL SWITCH	1
14	140539	NUT, 6-32 KEP	2
15	069764009	●SWITCH, ROLL THROTTLE	2
16	140019	WASHER, #6 EXT	2
17	140830	SCREW, 6-32 X 1-5/8	2
18	602886	PIN, SPRING RETURN	1
19	601118	SPRING, EXTENSION	1
20	200160014	NUT, M4 HXLCK	4
21	630104	SPEED CONTROL, PMB, 55 AMP	1
22	630261	SPACER, .19 X .31 X .50	2
23	630128	HEATSINK	1
24	601108	●SWITCH, TOGGLE MOM ON-ON 1 BAT	1
25	606059	DECAL, OPERATING INST.	1

REF	PART #	DESCRIPTION	QTY.
26	130776	●POTENTIOMETER	1
27	630304	SCREW, M4 X .7 X 35	2
28	605971	HANDLE, TUBE	1
29	605094	COLLAR, HANDLE	2
30	200823	●GRIP, HANDLE TUBE	2
31	140859	SCREW, 1/4-20 X 1/4	1
32	130753	●BOOT, SWITCH	1
33	606060	DECAL, REVERSE SWITCH	1
34	130775	POTENTIOMETER, 50K - LOCKABLE	2
35	230613	TUBE, HANDLE ADJUSTMENT	1
36	230649	PIN, HANDLE ADJUSTMENT	2
37	230648	PIN, HANDLE ADJUSTMENT LOCK	2
38	140415	SPRING, LOCK PIN	1
39	140351	SCREW, M12 X 1.75 X 70	2
40	140024	WASHER, 1/2 LCK	2
41	140045	WASHER, .510 X 1.25 X .06 FLT	2
42	140155	BUSHING, .481ID X 5/8 OD X 2"LG	2
43	607694	HOUSING, CONTROL CONSOLE, TEAL	1
44	626168	DECAL, SPEED CONTROL	1
45	601110	KNOB, SPEED CONTROL	1
46	140859	SCREW, 1/4-20 X 1/4	1
47	140554	SCREW, 1/4-20 X 3/4	1
48	605843	SLEEVE, ACTUATOR	1

▽ ASSEMBLY

▲ INCLUDED IN ASSEMBLY

● RECOMMENDED STOCK ITEMS

BRUSH GROUP

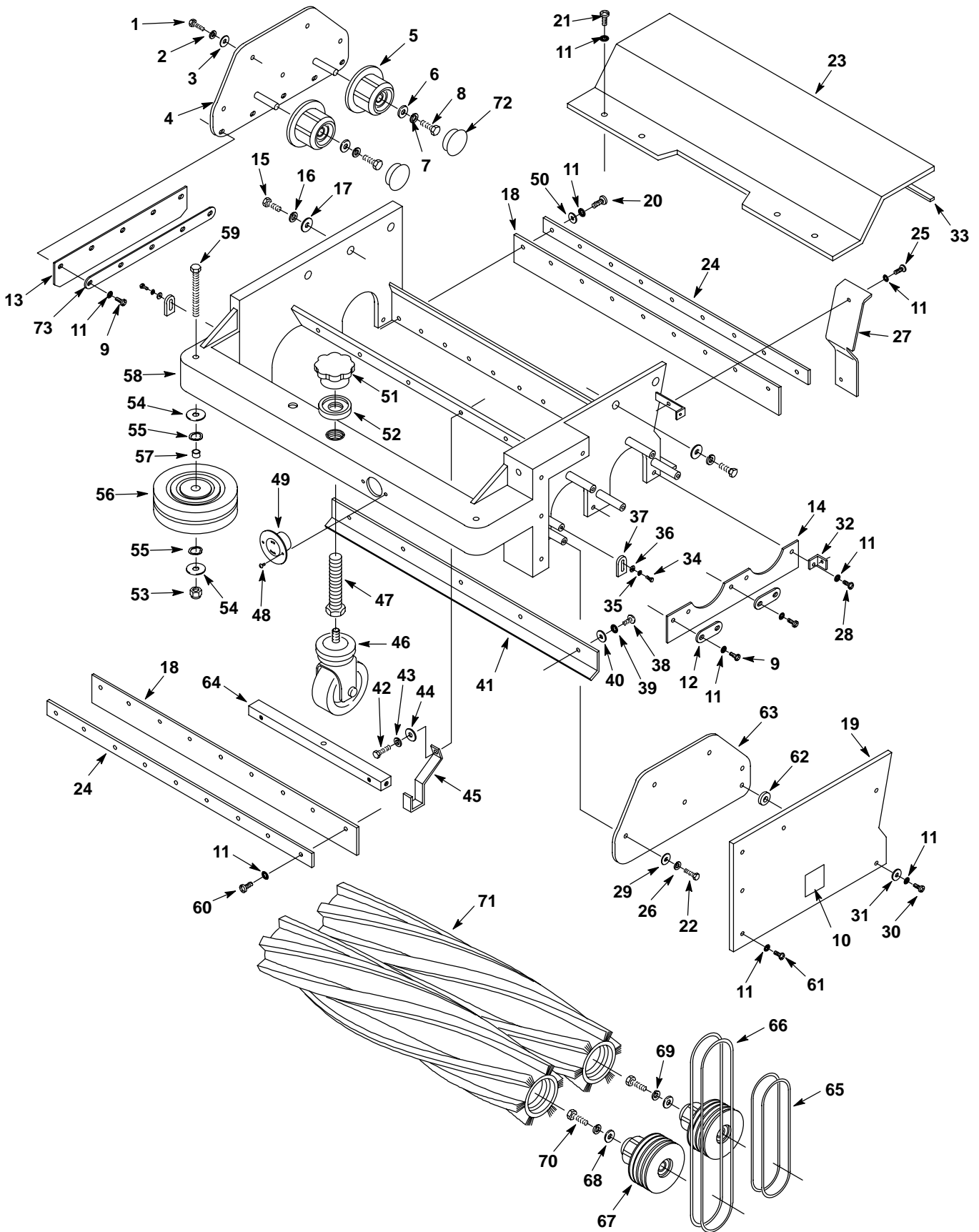



## BRUSH GROUP

REF	PART #	DESCRIPTION	QTY.
1	140276	SCREW, M10 X 1.5 X 16MM	5
2	140333	WASHER, M10 LOCK	5
3	140028	WASHER, 3/8 FLAT	5
4	231010	PLATE, BRUSH MOUNT RIGHT	1
5	607083	●BRUSH, PLUG	2
6	140003	WASHER, 1/4 X 1	2
7	140016	WASHER, 1/4 LOCK	2
8	140272	SCREW, M6 X 1.0 X 16	2
9	578141000	SCREW, M5 X .8 X 10	9
10	578769	DECAL, MOVING PARTS	2
11	140018	WASHER, #10 INT	49
12	231003	PLATE, SIDE SKIRT	2
13	607709	●SKIRT, RIGHT SIDE	1
14	101048	●SKIRT, LEFT SIDE	1
15	140352	SCREW, M12 X 1.75 X 25	5
16	140024	WASHER, 1/2 LOCK	5
17	140008	WASHER, 1/2 FLAT	5
18	600558	●SKIRT, FRONT/REAR	2
19	605861	PLATE, COVER LOWER	1
20	578141000	SCREW, M5 X 10	9
21	578141000	SCREW, M5 X .8 X 10	4
22	140276	SCREW, M10 X 1.5 X 16MM	5
23	606070	PLATE, FRONT COVER	1
24	600557	SKIRT, STRAP BLACK	2
25	578141000	SCREW, M5 X .8 X 10	2
26	140333	WASHER, M10	5
27	605857	PLATE, BELT GUARD	1
28	578141000	SCREW, M5 X .8 X 10	5
29	140028	WASHER, 3/8 FLAT	5
30	578302000	SCREW, M5 X 20 PANPHL	1
31	200315016	WASHER, 5.3 X 15.0 X 1.6 FLAT	1
32	605858	BRACKET, MOUNT BELT GUARD	1
33	606370	GASKET, STRIP, 24"	1
34	140272	SCREW, M6 X 1.0 X 16	2
35	140016	WASHER, 1/4 LOCK	2
36	140000	WASHER, 1/4 FLAT	2
37	605021	BLOCK, ADJUSTER	2

REF	PART #	DESCRIPTION	QTY.
38	069760096	SCREW, M8 X 1.25 X 10	5
39	200370019	WASHER, LOCK, INT, 08.41D	5
40	140027	WASHER, 5/16 FLAT	5
41	231009	PLATE, HOPPER CUT OFF	1
42	140275	SCREW, M8 X 1.25 X 16	5
43	140015	WASHER, 5/16 SPLTLCK	5
44	140027	WASHER, 5/16	3
45	600556	BRACKET, MANIFOLD	2
46	103051	●CASTER, FRONT SWIVEL	1
47	606512	STEM, CASTER	1
48	579237	SCREW, M4 X 12	2
49	606017	RECEPTACLE, TWIST LOCK	1
50	140011	WASHER, 3/16 FLAT	9
51	240202	●KNOB, HANDLE LOCK	1
52	230565	NUT, LOCK	1
53	200160018	NUT, HEX LOCK, M10	2
54	140036	WASHER, 3/8 FLAT	4
55	140060	WASHER, .505 X .750 X .045 WAVE	4
56	605373	WHEEL, 5 X 1 GRAY RUBBER	4
57	605956	BUSHING, BUMPER WHEEL	2
58	230966.BK	WELDMENT, CHASSIS	1
59	605986	SCREW, M10 X 1.5 X 130	2
60	578141000	SCREW, M5 X 10	9
61	578141000	SCREW, M5 X .8 X 10 PANPHL	5
62	605985	SPACER, NYLON	1
63	231011	PLATE, BRUSH MOUNT LEFT	1
64	607470	●SPRAY BAR ASSEMBLY*	1
65	230989	●BELT, ROUND .312DIA X 29.25 92AE	2
66	230988	●BELT, ROUND .312DIA X 48.50 92AE	2
67	604061	●PULLEY, W/ DRIVE LUG	2
68	140003	WASHER, 1/4 X 1	2
69	140016	WASHER, 1/4 LCK	2
70	140272	SCREW, M6 X 1.0 X 16	2
71	606930	●BRUSH, 23"x6"	2
72	607708	●DUST CAP, 1.40" DIA	2
73	607710	STRAP, SKIRT RIGHT SIDE	1

\* SEE PLUMBING GROUP

● RECOMMENDED STOCK ITEMS

FAN/BRUSH MOTOR GROUP

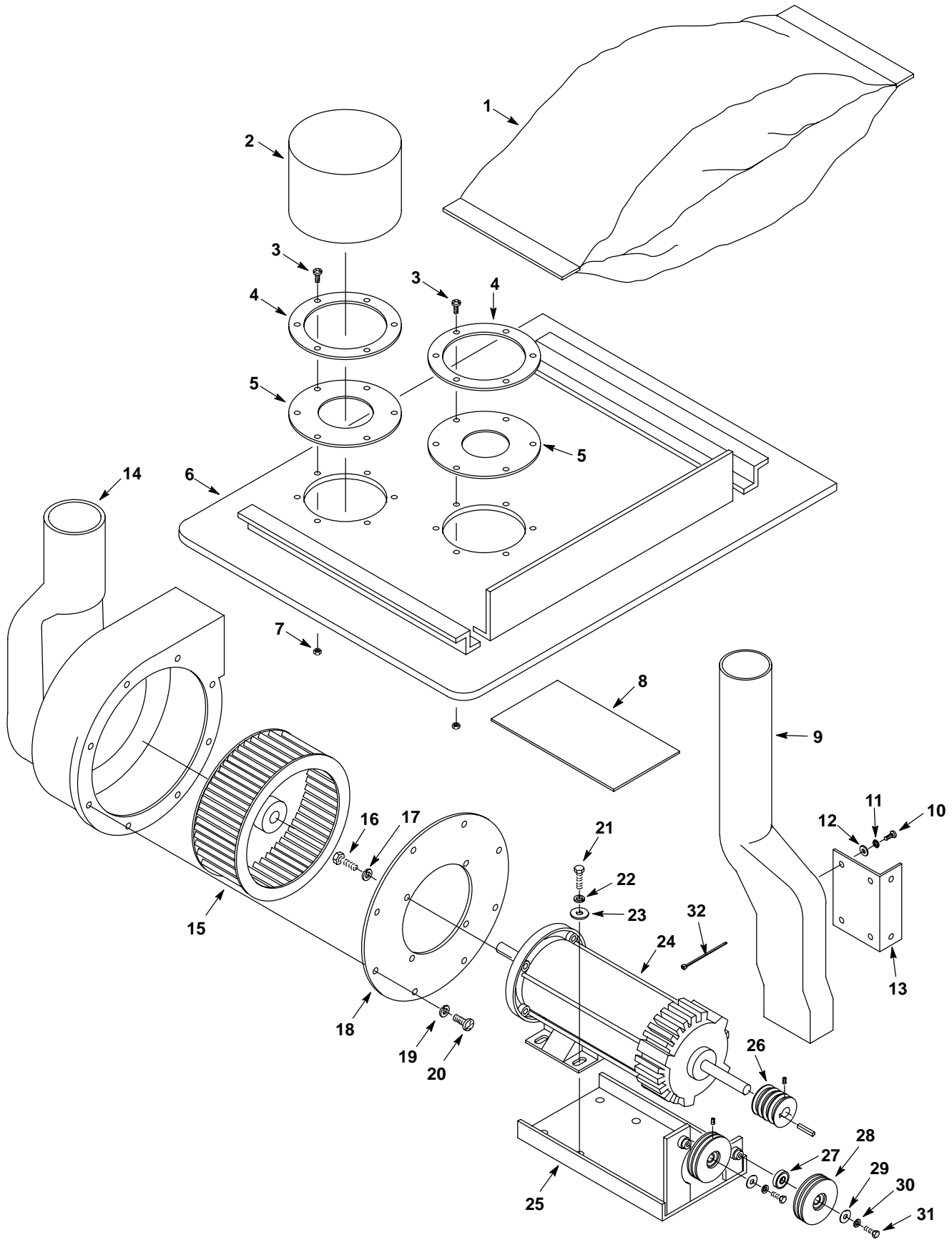

## FAN/BRUSH MOTOR GROUP

REF	PART #	DESCRIPTION	QTY.
1	602604	●BAG, DISPOSABLE PAPER (5-PACK)	1
2	101043	●FILTER, INTAKE 60 PORE FOAM	1
3	578187000	SCREW, M6 X 1.0 X 12	12
4	602588	SEAL, PLATE	2
5	101045	●SEAL	2
6	230972.BK	PLATE, SEAL	1
7	140284	NUT, M6 X 1.0 NYLCK	12
8	605862	INSULATOR, SEAL PLATE	1
9	101030	AIR DUCT HOUSING	1
10	578141000	SCREW, M5 X 10	6
11	140018	WASHER, #10 INT	6
12	140011	WASHER, 3/16 FLT	6
13	600433	BRACKET, AIR DUCT	1
14	101117	FAN HOUSING	1
15	230987	BLOWER WHEEL, 10" DIA 3" WIDE	1
16	140200	SCREW, 3/8-16 X 1/2	4

REF	PART #	DESCRIPTION	QTY.
17	140022	WASHER, 3/8 INT	4
18	231007	PLATE, FAN HOUSING MOUNT	1
19	140018	WASHER, #10 INT	8
20	578141000	SCREW, M5 X 10	8
21	200031488	SCREW, M8 X 1.25 X 20	4
22	140015	WASHER, 5/16 SPLTLCK	4
23	140027	WASHER, 5/16 FLT	4
24	130036	MOTOR, BRUSH\FAN 1.5HP 24VDC	1
25	231012	BRACKET, MOTOR MOUNT	1
26	231018	PULLEY, MOTOR	1
27	140123	BEARING, BRUSH	2
28	231019	PULLEY, IDLER	2
29	630303	WASHER, FLAT	2
30	140015	WASHER, 5/16 SPLTLCK	2
31	200031483	SCREW, M8 X 1.25 X 12 HXHDCP	2
32	130040	WIRE TIE	1

● RECOMMENDED STOCK ITEMS

ELECTRICAL PANEL GROUP

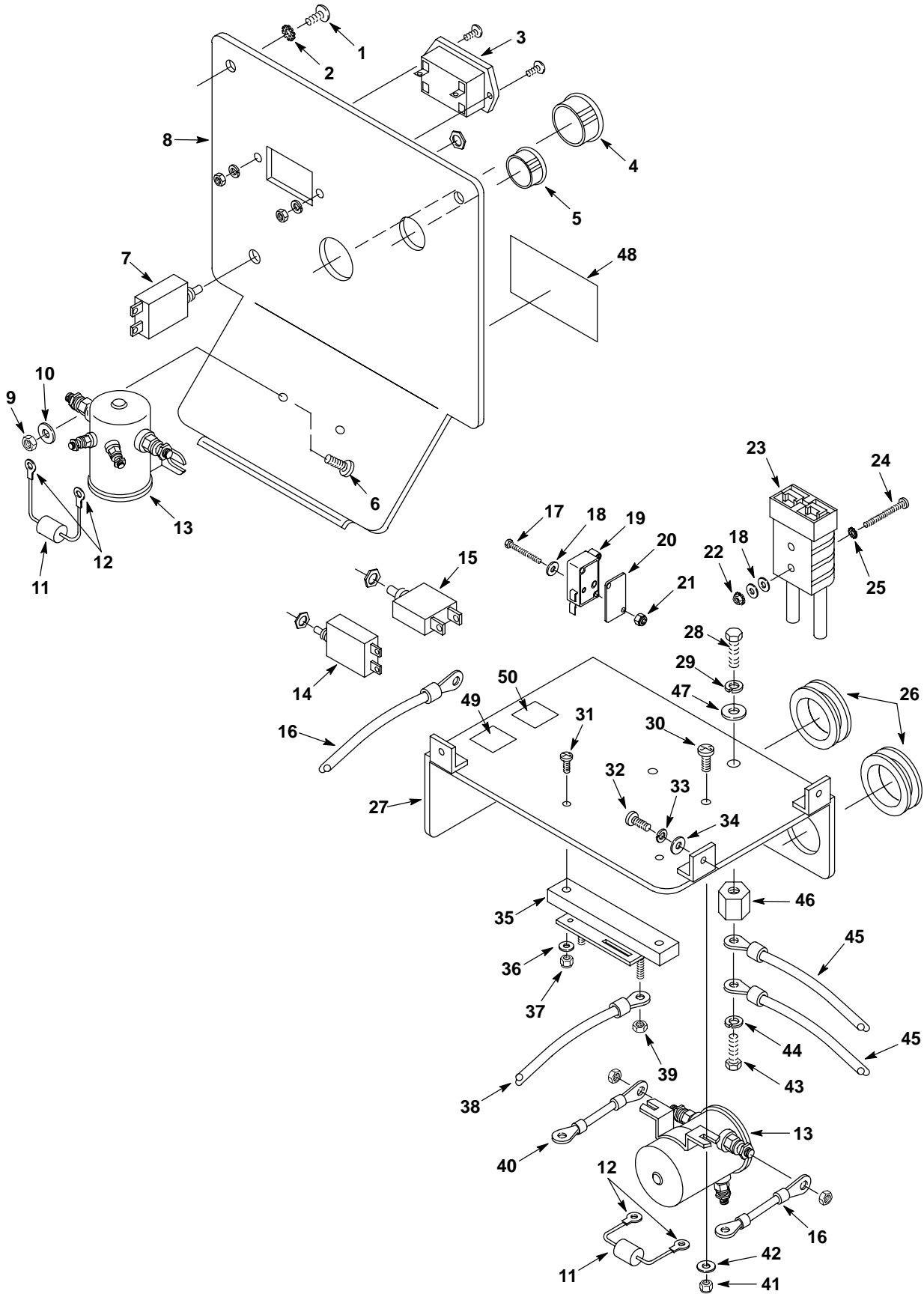

## ELECTRICAL PANEL GROUP

REF	PART #	DESCRIPTION	QTY.
1	578141000	SCREW, M5 X .8 X 10	2
2	140018	WASHER, #10 INT	2
3	630143	METER, HOUR, 18-60 VDC	1
4	130161	PLUG, DOME .875 OD - BLACK	1
5	130175	PLUG, DOME .750 OD - BLACK	1
6	578187000	SCREW, M6 X 1.0 X 12	2
7	578337000	●CIRCUIT BREAKER, 1.5A	1
8	605022	PANEL, REAR COVER	1
9	140284	NUT, M6 X 1.0 NYLCK	2
10	140000	WASHER, 1/4 FLT	2
11	130423	●DIODE, 400V/6.0A SILCONE	2
12	130125	TERMINAL RING, #10	4
13	130218	●SOLENOID, 24 VOLT	2
14	603487	●BREAKER CIRCUIT, BRUSH 15AMP	1
15	130739	●BREAKER, CIRCUIT-MASTER 60 AMP	1
16	605908	ASM, WIRE #6X47" RED 1/4R-5/16	2
17	578403000	SCREW, M3 X .5 X 20	2
18	140032	WASHER, #6 FLAT	6
19	600437	●SWITCH, ROLLER 15A	1
20	601359	PLATE, SWITCH BACKING	1
21	579211	NUT, M3 HEXLCK	2
22	140539	NUT, 6-32	2
23	605906	●CABLE, BATTERY & RED CHARGEPLUG	1
24	140829	SCREW, 6-32 X 1	2
25	140019	WASHER, #6 EXT	2

REF	PART #	DESCRIPTION	QTY.
26	069762009	GROMMET, DIA 25.4 X 03 GROOVE	2
27	605949	BRACKET, SOLENOID MOUNT	1
28	140553	SCREW, 1/4-20 X 1/2	1
29	140016	WASHER, 1/4 LCK	1
30	578321000	SCREW, M6 X 1.0 X 16	2
31	578302000	SCREW, M5 X 20	2
32	578141000	SCREW, M5 X .8 X 10	3
33	140018	WASHER, #10 INT	3
34	140011	WASHER, 3/16 FLT	3
35	605292	SHUNT	1
36	140011	WASHER, 3/16 FLT	2
37	140283	NUT, M5 X .8 NYLCK	2
38	605911	ASM, WIRE #6X16"RED 1/4R-5/16R	1
39	140524	NUT, 1/4-20 KEP	2
40	605913	ASM, WIRE #6X3"RED 1/4R-5/16R	1
41	140284	NUT, M6 X 1.0 NYLCK	2
42	140000	WASHER, 1/4 FLT	2
43	140259	SCREW, 1/4-20 X 5/8	1
44	140016	WASHER, 1/4 LCK	1
45	605910	ASM, WIRE #6X18"BLK 1/4R-5/16R	2
46	578427	STANDOFF, TERMINAL	1
47	140000	WASHER, 1/4 FLAT	1
48	120649	DECAL, WARNING	1
49	606400	DECAL, BRUSH CIRCUIT BREAKER	1
50	604795	DECAL, MAIN CIRCUIT BREAKER	1

● RECOMMENDED STOCK ITEMS

HOPPER AND DRIVE GROUP

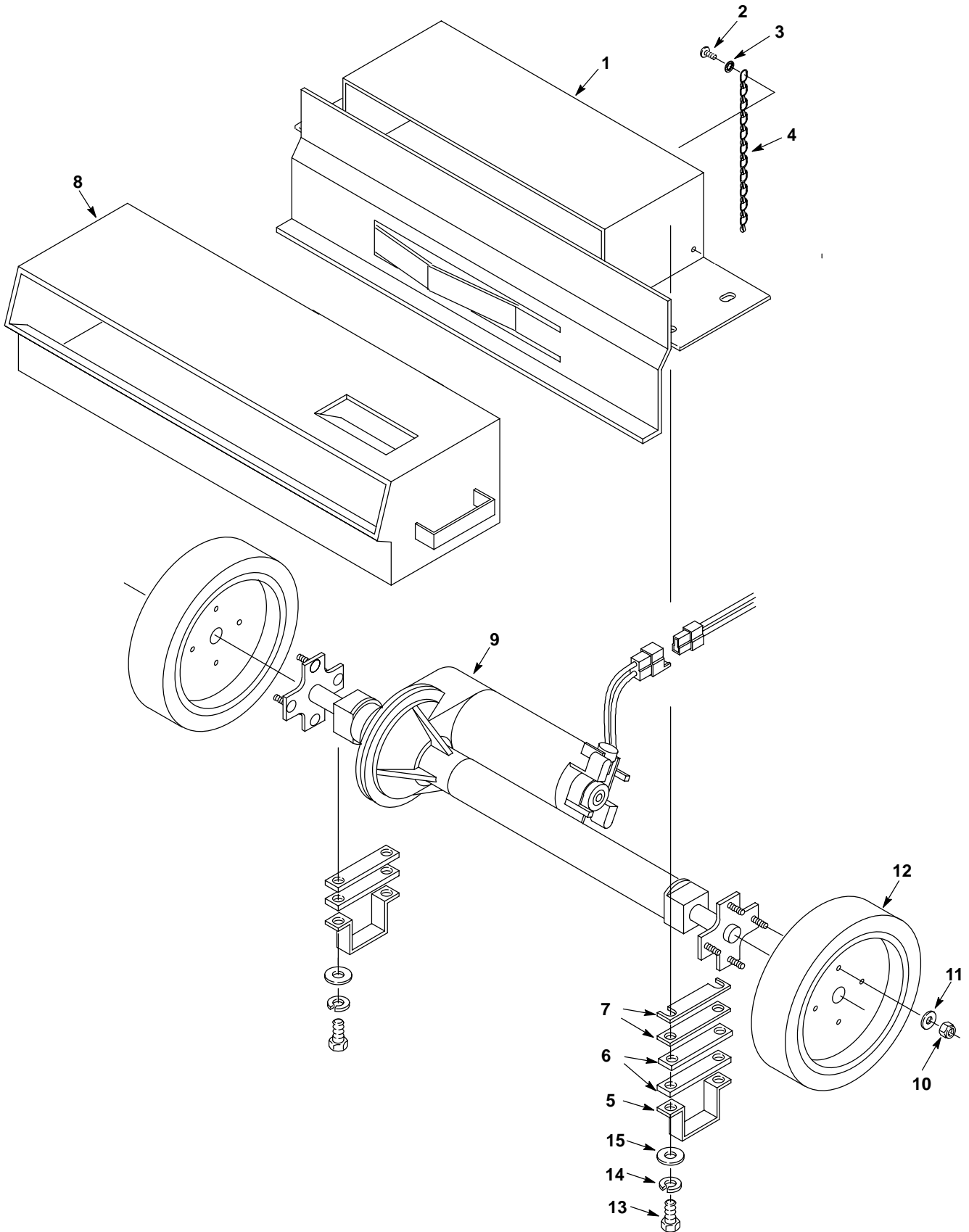

## HOPPER AND DRIVE GROUP

REF	PART #	DESCRIPTION	QTY.
1	230969.BK	BRACKET, WHEEL	1
2	579237	SCREW, PANHD, PHIL, M4 X 12	2
3	140023	WASHER, #8 INT	2
4	605950	CHAIN LINK, 8"	2
5	602881	BRACKET, TRANSAXLE MOUNT	2
6	231001	PLATE, AXLE	4
7	605951	PLATE, AXLE SHIM 1/16"	2
8	600559	HOPPER, SWEEPER	1

REF	PART #	DESCRIPTION	QTY.
9	130039	TRANSAXLE & MOTOR 24 VDC	1
10	630268	NUT, 1/4-28 HEXLCK	8
11	140000	WASHER, 1/4 FLT	8
12	640013	●WHEEL, 8"DIA, 2"WIDE, NEOPRENE	2
13	200031496	SCREW, M8 X 1.25 X 35	4
14	140015	WASHER, 5/16 SPLTLCK	4
15	140027	WASHER, 5/16 FLT	4

● RECOMMENDED STOCK ITEMS

PLUMBING GROUP

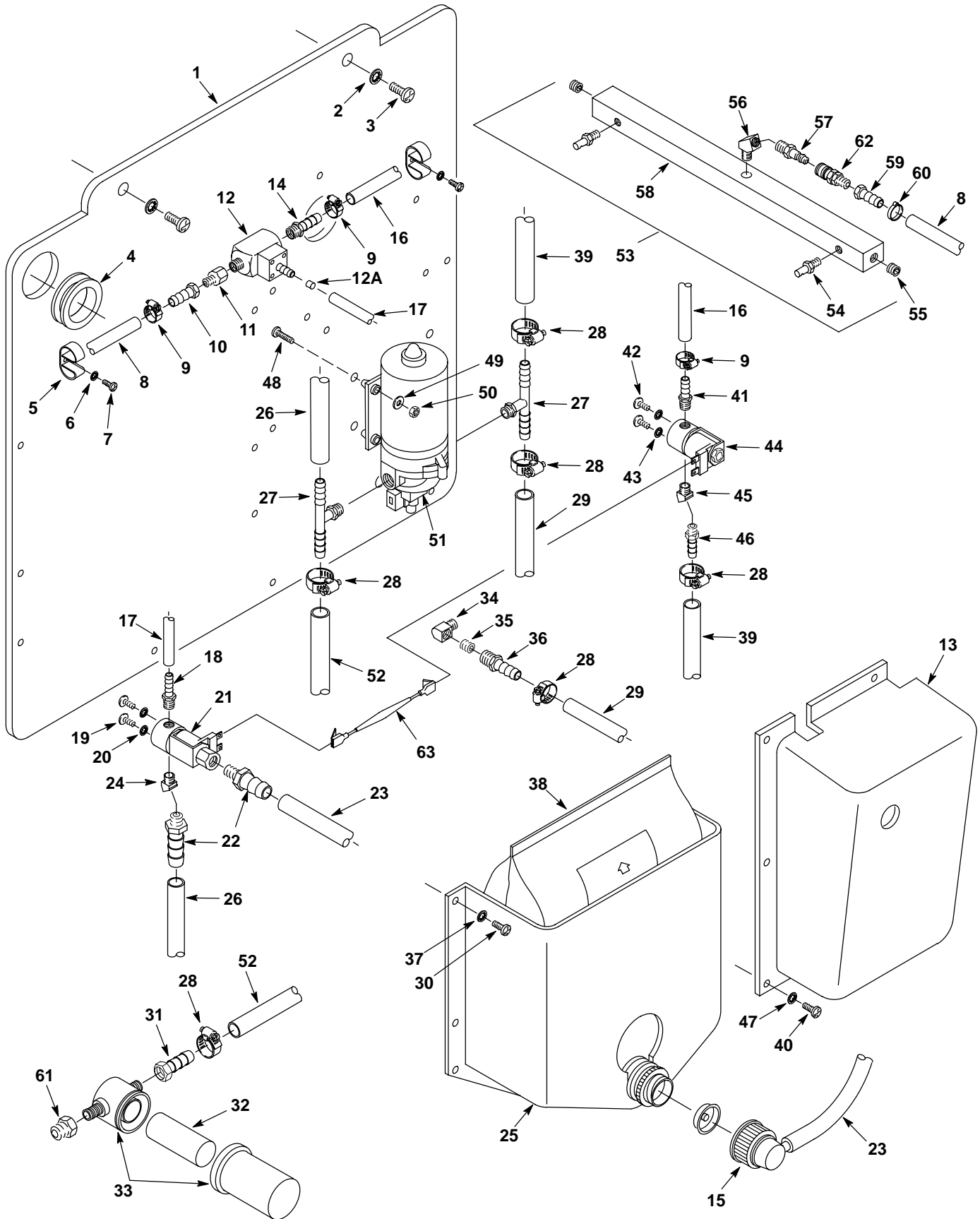



## PLUMBING GROUP

REF	PART #	DESCRIPTION	QTY.
1	605072	PANEL, REAR	1
2	578244000	WASHER, 6.4 X 10.0 LOCK	4
3	578187000	SCREW, M6 X 1.0 X 12	4
4	069762009	GROMMET, DIA 25.4 X 03 GROOVE W	2
5	600215	GRIPPER, CLIP	2
6	140018	WASHER, #10 INT	2
7	578141000	SCREW, M5 X 10	2
8	606364	HOSE, 1/4 LP GRAY, 5'	1
9	140305	CLAMP, HOSE 7/32-5/8 DIAM	3
10	150520	FITTING, 1/8F X 1/4H BARB	1
11	603517	VALVE, CHECK 1/8FPT X 1/8 MPT	1
12	603544	●INJECTOR, W/#3 NOZZLE	1
12A	604786	●REPLACEMENT METERING TIP (ORANGE), STANDARD	1
	600823	●REPLACEMENT METERING TIP (TAN), ALTERNATE	1
	607352	●REPLACEMENT METERING TIP (TUR-QUOISE), ALTERNATE	1
13	605019	COVER, PLUMBING/ INJECTOR	1
14	150525	FITTING, 1/8M X 1/4 BARB	1
15	606023	●SWIVEL CAP WITH 3/8" BARB	1
16	606359	HOSE, 1/4 LP GRAY, 8"	1
17	606360	TUBING, 1/4ID CLEAR VINYL, 8"	1
18	150525	FITTING, 1/8M X 1/4 BARB	1
19	140801	SCREW, 8-32 X 3/8	2
20	140023	WASHER, #8 INT	2
21	606021	●VALVE, SOLENOID 24V 3-WAY	1
22	606052	FITTING, 1/8"NPTM X 3/8"H. BARB	2
23	606361	TUBING, MAYON PLAS 3/8 X .125 X 13"	1
24	150422	FITTING, 1/8M X 1/8F ELBOW 45°	1
25	606016	COVER, BAG HOLDER	1
26	606362	TUBING, MAYON PLAS 3/8 X .125 X 6.5"	1
27	150715	TEE, MALE BRANCH 3/8H X 3/8 NPT	2
28	140310	CLAMP, HOSE 5/16-7/8	6
29	160497	TUBING, 5/8OD X 3/8ID X 6"	1

REF	PART #	DESCRIPTION	QTY.
30	578141000	SCREW, M5X10 PANPHL	7
31	150511	FITTING, 1/4F X 3/8H BARB	1
32	180638	●SLEEVE, FILTER	1
33	180619	●FILTER, 1/4NPT CLR BOWL	1
34	150406	FITTING, 1/4M X 1/4F ELBOW 90°	1
35	602980	PLUG, MOD .150208 5/64 DIA	1
36	150016	ADAPTER, FTG 1/8FX3/8H	1
37	140018	WASHER, #10 INT	7
38	606025	●POUCH, SOLUTION (CASE OF 4)	1
39	160497	TUBING, 5/8OD X 3/8ID-NYLOBRDE X 6"	1
40	578141000	SCREW, M5X10 PANPHL	5
41	150515	FITTING, 1/4MX1/4H BARB BRS	1
42	140801	SCREW, 8-32X3/8	2
43	140023	WASHER, #8 INT	2
44	603030	●SOLENOID, WATER 24VDC	1
45	150403	FITTING, 1/4MX1/4F ELBOW STRT45	1
46	150516	FITTING, 1/4MX3/8H BARB	1
47	140018	WASHER, #10 INT	5
48	140266	SCREW, M5X.8X25MM PAN	4
49	140012	WASHER, 3/16 FLT	4
50	140283	NUT, M5X.8 NYLCK	4
51	603031	PUMP, 100PSI 24VDC	1
52	606363	TUBING, 5/8OD X 3/8ID X 13"	1
▽53	607470	●ASM., SPRAY BAR	1
▲54	201016	●NOZZLE, FLOODJET	2
▲55	150208	FITTING, 1/8M PLUG	2
▲56	150422	FITTING, 1/8M X 1/8F ELBOW 45°	1
▲57	150921	●FITTING, 1/8M QD COUPLER	1
▲58	605020	MANIFOLD, 2 JET	1
59	150520	FITTING, 1/8F X 1/4H BARB	1
60	140325	CLAMP, EAR 1/2" S/S	1
61	150006	FITTING 1/4F X 3/8M BUSHNG, BRASS	1
62	150915	●FITTING, 1/8 QD COUPLER	1
63	609989	ASM, WIRE/DIODE	1

● RECOMMENDED STOCK ITEMS

▽ ASSEMBLY

▲ INCLUDED IN ASSEMBLY

SIDE BRUSH GROUP

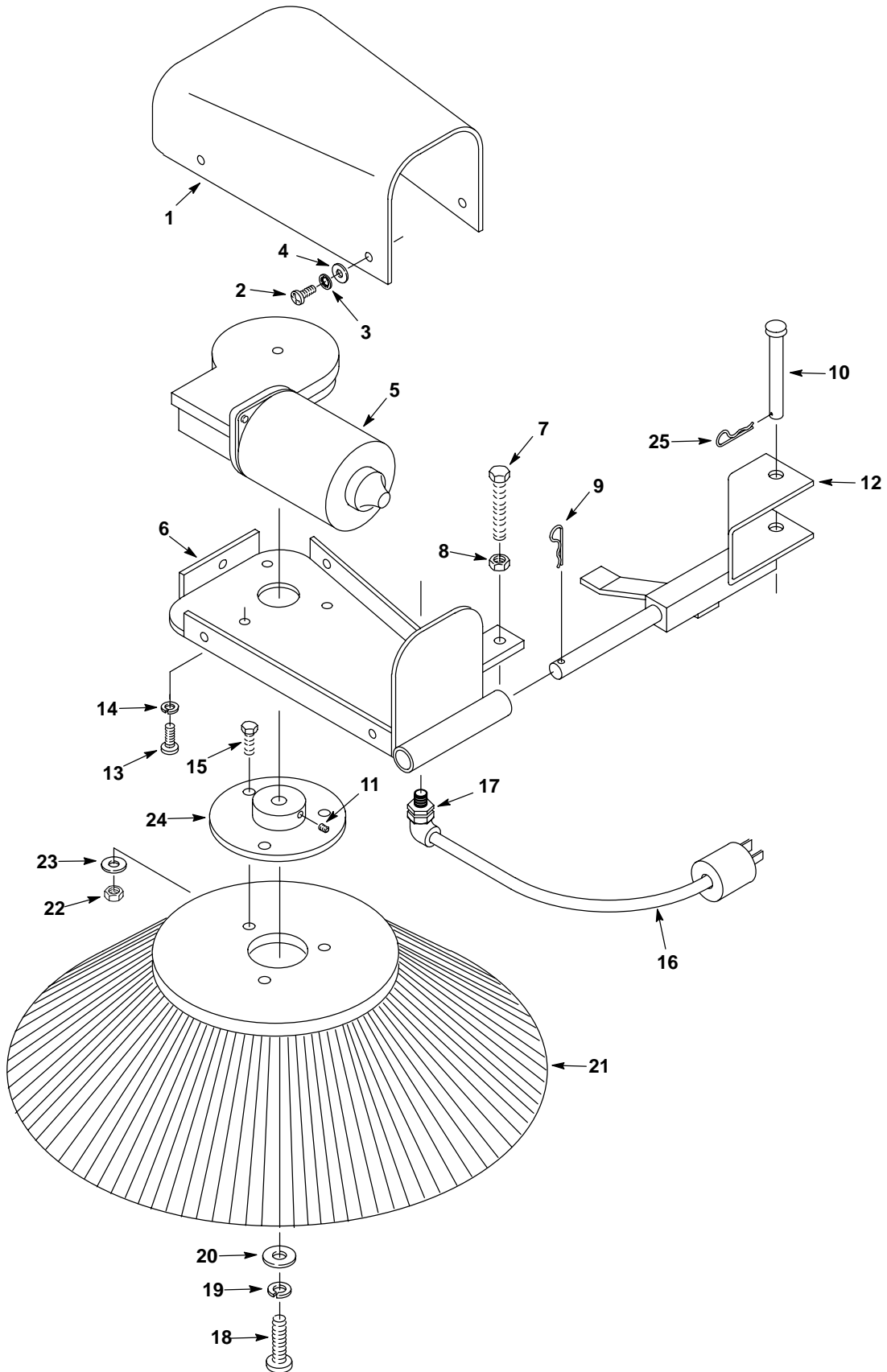

## SIDE BRUSH GROUP

REF	PART #	DESCRIPTION	QTY.
▽	607472	●ASM., SIDE BRUSH	1
▲1	101049	COVER, SIDE BROOM	1
▲2	578187000	SCREW, M6 X 1.0 X 12	5
▲3	578244000	WASHER, 6.4 X 10.0	5
▲4	140000	WASHER, 1/4 FLAT	5
▲5	130037	MOTOR, SIDE BROOM 24VDC	1
▲6	231013.BK	BRACKET, SIDE BROOM MOUNT	1
▲7	601094000	SCREW, M10 X 1.5 X 45	1
▲8	140285	NUT, HEX M10 X 1.5	1
▲9	578421	●PIN, COTTER, .12 X 1.00"	1
▲10	601471	PIN, CLEVIS .5 X 2.5	1
▲11	200252432	SCREW, M6 X 1.0 X 10 SET	1
▲12	600560	BRACKET, PIVOT, SIDE BROOM	1
▲13	578187000	SCREW, M6 X 1.0 X 12	3

REF	PART #	DESCRIPTION	QTY.
▲14	578244000	WASHER, 6.4 X 10.0	3
▲15	140272	SCREW, M6 X 1.0 X 16	3
▲16	606068	●ASM, WIRING, SIDE BROOM	1
▲17	130194	RELIEF, STRAIN	1
▲18	578141000	SCREW, M5 X 10	1
▲19	140018	WASHER, #10 INT	1
▲20	200315016	WASHER, 5.3 X 15.0 X 1.6 FLAT	1
▲21	027616000	●BRUSH, SIDE	1
▲22	140284	NUT, M6 X 1.0 NYLOCK	3
▲23	140000	WASHER, 1/4 FLAT	3
▲24	231020	HUB, SIDE BROOM	1
▲25	140626	PIN, HITCH	1

● RECOMMENDED STOCK ITEMS

▽ ASSEMBLY

▲ INCLUDED IN ASSEMBLY



LADDER DIAGRAM 24V

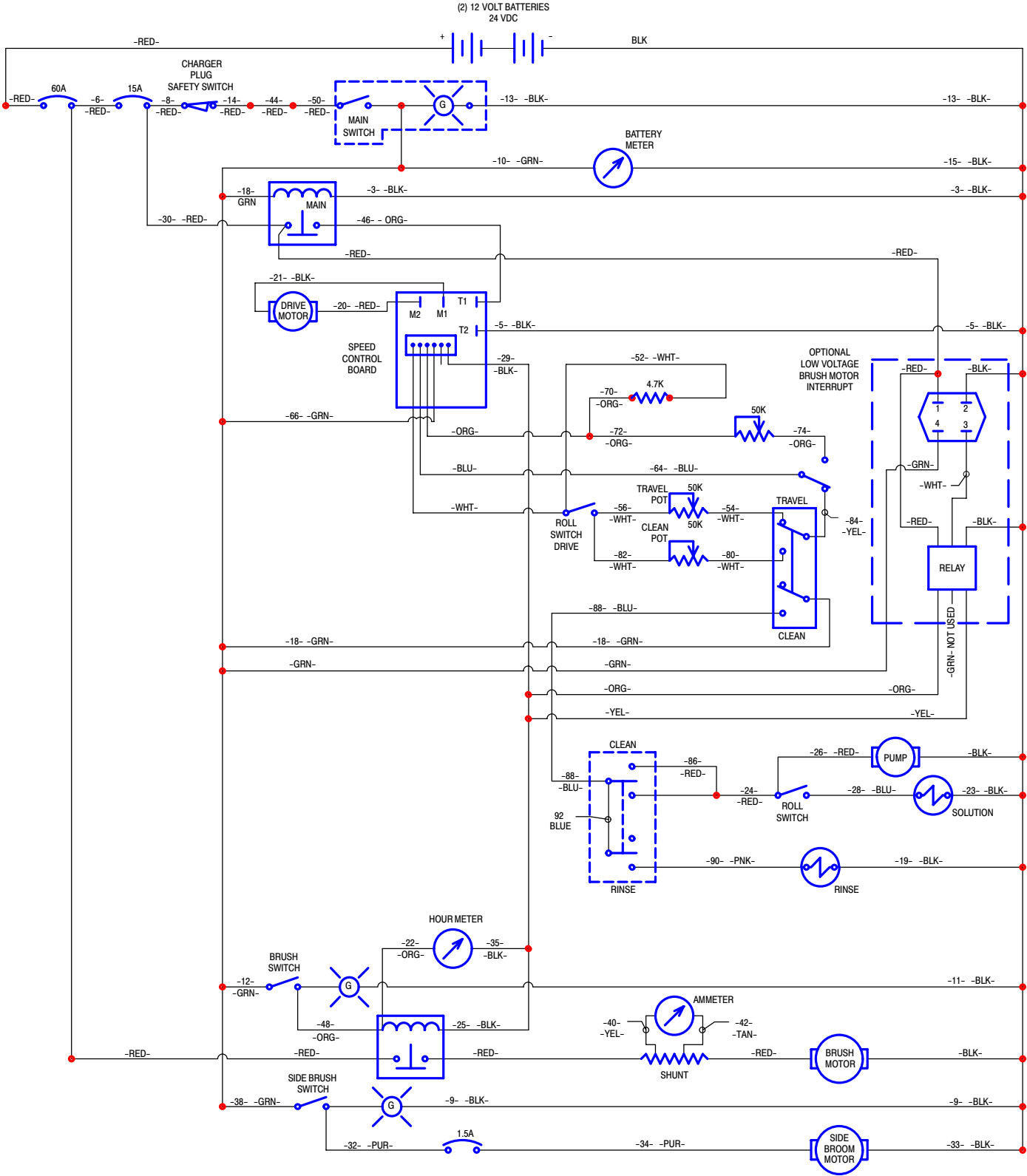

EMERGENCY STOP & KEY SWITCH KITS

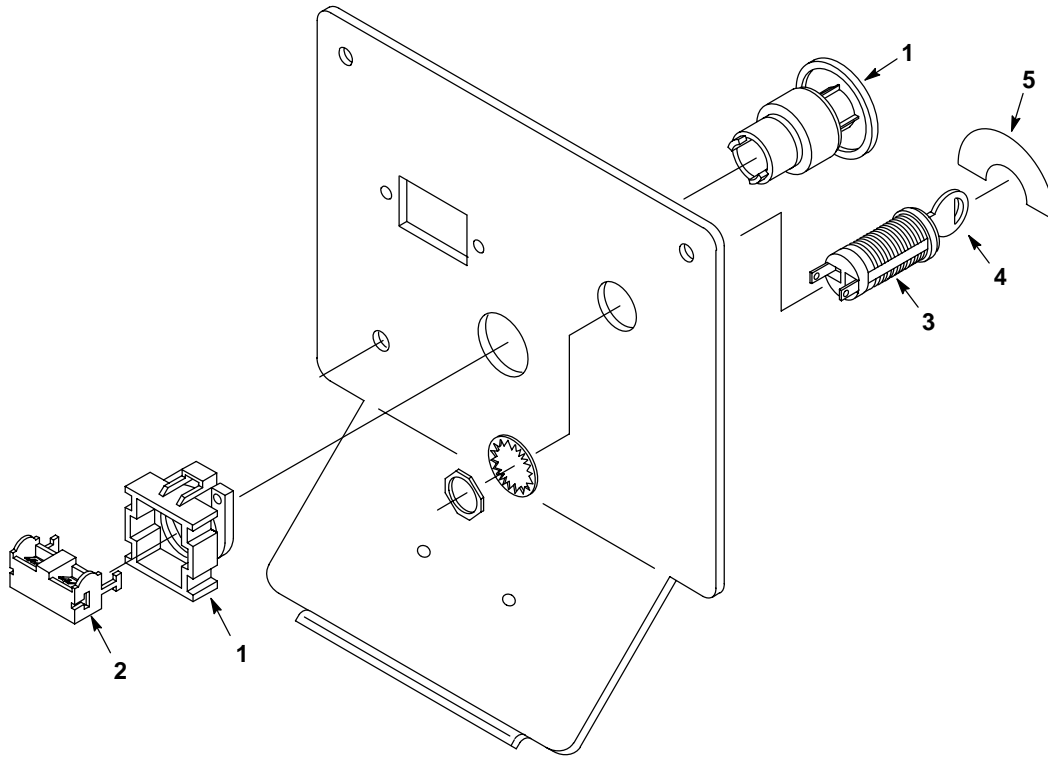

REF	PART #	DESCRIPTION	QTY.
▽	602995	KIT, EMERGENCY STOP	1
▲1	630100	SWITCH, EMERGENCY STOP	1
▲2	630097	SWITCH, CONTACT BLOCK	1
▲N/S	602996	ASM WIRE #16X5" RED 1/4FX1/4F	1
▲N/S	602997	ASM WIRE #16X5" RED 1/4MX1/4F	1
▲N/S	602998	INSTRUCTION SHEET, E-STOP INSTALL	1

REF	PART #	DESCRIPTION	QTY.
▽	602993	KIT, KEYSWITCH	1
▲3	612462	SWITCH, KEY	1
▲4	069762236	KEY	1
▲N/S	603006	INSTRUCTION SHEET, KEYSWITCH	1
5	604793	DECAL, KEYSWITCH ON/OFF	1

▽=ASSEMBLY

▲=INCLUDED IN ASSEMBLY

N/S=NOT SHOWN